



CATALOGUE

Innovative mobility solutions & products





Intelligently simple, smart product design.



Contents

Our story	2	Medical castors	34	Tugs and Movers	64
Innovative mobility solutions and products	4	Products imagined by you. Custom made by us.....	35	Choosing a Tug or Mover.....	66
Australian made	5	Trinity.....	36	Powered Tugs	68
Your move safe solution in Healthcare.....	6	Trinity Electronic Braking Castors.....	37	Bed Movers.....	71
General castors	8	Trinity and Trinity EBC fittings and order codes.....	38	Linen Movers.....	73
L Series—30 kg	9	Central locking castor options for hospital beds.....	40	Meal System Movers	75
Twin Series—40 kg	10	Wheelchair castors	42	Powered Fifth Wheel.....	76
N Series—90 kg	10	Conductive (anti-static) wheels.....	42	Bin Lifters	78
K Series—100 kg	11	Decorative castors	43	Liftmaster Bin Lifters.....	80
M Series—200 Kg	12	Arc range.....	44	Wheelie bin transport.....	80
Big M Series—200 kg.....	14	Zen range.....	46	Information	82
Customising K and M Series	15	M Deluxe range.....	47	Trading Policies.....	83
J Series—300 kg	16	Build your own castor	48	Test summaries for wheels and castors.....	84
Y Series—180 kg	17	Wheels	50	Test summaries for materials handling equipment	86
O Series—500 kg	18	Hard wheels	51	Delivery Policy.....	87
H Series—600 kg	20	Polyurethane wheels.....	52	Maintenance and Fitting	88
Waste Bin Series—400 kg	21	Soft wheels	52	Preventative maintenance, breakdown repair service, fitting.....	89
X Series—1000 kg	22	Pneumatic wheels.....	54	Warranty.....	90
V Series—2450 kg	23	Pneumatic puncture proof wheels	55	Conditions of use.....	91
A Series—3500 kg	23	Pneumatic steel centred wheels	56	Choosing castors and wheels.....	92
Specialised castors	24	Pneumatic plastic centred wheels	57	Castor code structure	94
AGV Cart Castors 500 kg.....	25	Fittings and spares	58	Fork mount dimensions	95
Corrosion resistance	26	Fittings for 10 mm and 12 mm bolt hole castors.....	59	Injury reduction strategies.....	96
M Powder coat.....	27	Fittings for 12 mm bolt hole castors	60		
M Stainless Steel	28	Spares for pneumatic wheels and general wheels	61		
O Stainless Steel.....	30	General spares	62		
High and low temperature castors.....	31				
M, J, O Series High/Low Temperature	32				

Our story

Innovative Mobility Solutions

We are a single-source solution provider in mobile applications.

We're experts in mindful moving. We can help our customers to improve safety, productivity and profit in any process that involves pushing, pulling or lifting:

- We work with healthcare, commercial and industrial original equipment manufacturers (OEM) to offer components or complementary products that either reduce the lowest total cost of ownership or provide enhanced product features that increase the saleability or value of their OEM equipment.
- We work with healthcare facilities to improve outcomes in their push-pull processes and patient safety.
- We work with industrial end users to improve their move-safe processes.





Both Fallshaw & Electrodrive have engineering roots and proud histories of making products to world standards.

The company was founded by Percy Fallshaw who started making wheelchairs in 1920.



It was then managed for 45 years by Robert Fallshaw, under whose leadership we started making castors, developed our manufacturing expertise and built an enviable sales network to become one of the world's leading castor companies. Regrettably Robert passed away in 2005.



Jo Fallshaw, Robert's daughter, is now the Managing Director and owner, and continues the tradition of developing innovative products, and manufacturing well-designed, cost effective, quality castors, delivered in-full and on-time with great service and technical support.

In 2012, Jo Fallshaw acquired Electrodrive, with its own proud history in design, manufacture and servicing of powered materials handling products.

This has enabled Fallshaw and Electrodrive to combine product portfolios and expertise to expand into the broader portfolio of mobility solutions and products.





Innovative mobility solutions and products

We have intelligently simple, smart product design. Our mobility products are deceptively simple and elegant. The interface is intuitive and easy to use.

We design for form and function, with contemporary styling and without unnecessary components or material.

Our products are not constrained by traditional approaches.

We enjoy doing things differently. We think anew about material selection and manufacturing technology and we radically reinterpret mobility product design.

Our greatest compliment is when our customers forget about our mobility products—what do we mean by that?

- Bed movers should have control panels so intuitive that you don't need to read the instruction manual or require more than 5 minutes of training
- Furniture castors should be a considered part of furniture design, with colour, finish and style seamlessly blending to the point that the castors are just a part of the whole, rather than an afterthought
- Castors used on trolleys should steer true with minimal push effort, great ride comfort and brakes that work effectively every time—when castors are designed well people are not conscious of how a trolley moves—it just happens
- Serious working castors should have long product life with minimal and easy preventative maintenance—castors should not cause interruptions to equipment use due to high wear rates or breakdowns: they should soldier on unnoticed

When you choose Fallshaw castors or Electrodrive materials handling equipment, you can then forget about them—they are designed to perform.

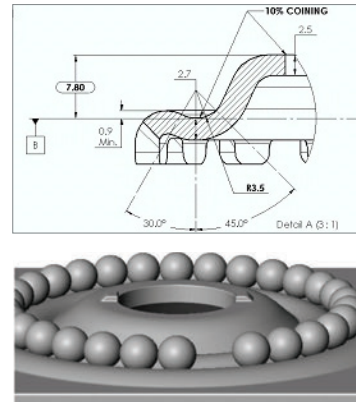

Quality basics of Fallshaw castors

- A 5 year warranty on the fork and 3 years on the wheel
- Best practice corrosion resistance (150 hours in salt spray test)
- Attention to detail and quality materials:
 - Stainless steel brake springs (not heat-treated mild steel that can embrittle)
 - Steel that is pickled and oiled (not black steel with associated streaky-plating)
 - Coined ball tracks to prevent brinelling (stops sloppy castors as ball tracks wear-down)
 - Head race rivets in high-quality steel that won't elongate or snap under impact
 - UV stabilisers in plastic parts so colours stay true and parts don't become brittle

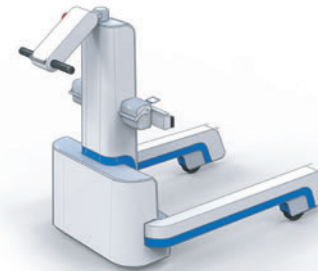

Quality basics of Electrodrive materials handling equipment

- All electro-hydraulic and electronic components are load and cycle tested in worst-case environments
- Motors designed for continuous operation (S1 rating with venting to prevent heat build-up and alloy steel gearing for long life)
- Sealed gel cell battery for transport without leakage and prevention of the risk of acid leakage
- Easy access to core service components (clustered electronic components via easy access panels to fuses, motor controllers, short stop, hour meter etc.)
- Programmed and programmable speed control so that start-up and slow-down speeds are safe, non-threatening and can be altered to suit particular applications and (of course) wheels & castors have high-abrasion tyres and quality bearings to ensure long product life

Australian made

Manufacturing capability

Our manufacturing plant is located in one complex in Melbourne, Australia. We are able to produce products at world competitive prices because we use intelligent technology, a highly skilled and productive workforce and lean manufacturing methodology to reduce costs.

While wheels and forks are assembled to stock, castors are assembled to order. We pick the wheels and forks (either sold separately or assembled as castors) which makes for a rapid turnaround.

We injection mould and assemble the wheels, where automation and a highly skilled workforce enable fast lead times and flexible processes. We also have our own test facility where we ensure that our wheels and castors perform in the harshest conditions.

We also press metal form and fabricate fork components before the forks are assembled. Progressive tools with leading edge processes and controls, precision welding robots and tight tolerance control result in efficiently produced, quality metal components.

Both Fallshaw and Electrodrive have Quality Management Systems certified to ISO 9001:2008, and we manufacture the vast majority of our products in Australia (upwards of 85% overall at time of printing).

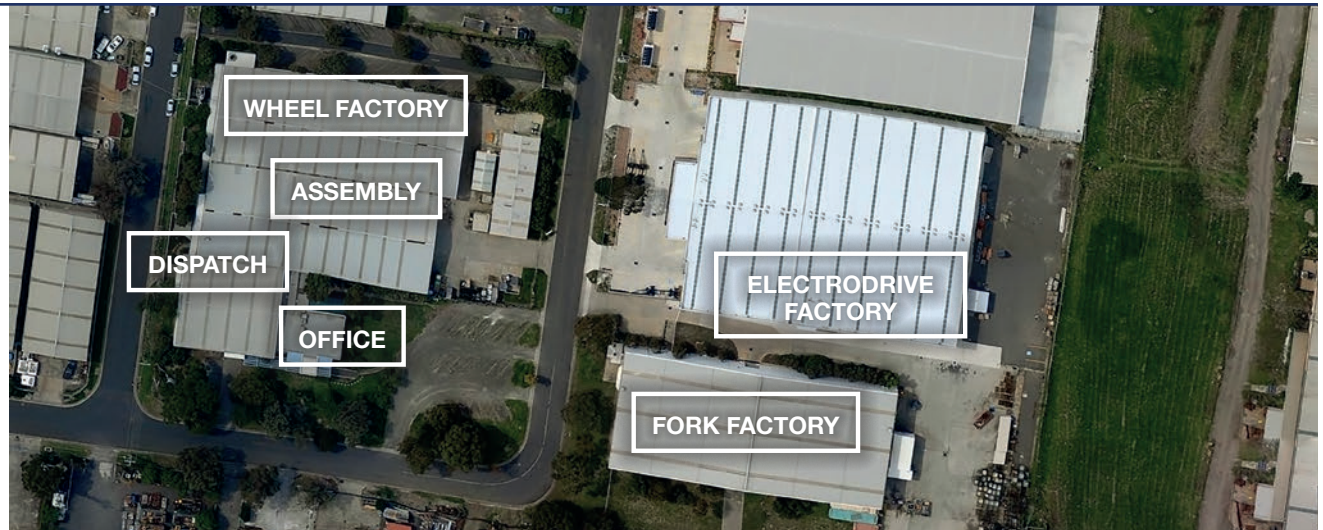

Your move safe solution in Healthcare



Whether you're moving beds, linen, food or waste, we can help your staff to stay safe, and demonstrate compliance with the Australian Government's *Hazardous Manual Tasks, Work Health and Safety Code of Practice*.

We are the experts in mindful moving

We work with Healthcare facilities to improve safety outcomes in their push-pull processes and patient safety.

We are a single-source solution provider in mobile applications with intelligently simple, smart product design.

We have a branch network in Brisbane, Sydney and Melbourne, and an Australia-wide service network to support our rock-solid warranty and offer preventative maintenance programs.

We have solutions to prevent push/pull injuries effecting the shoulder, back, neck, arm, forearm/wrist, knee, and hand and fingers.

The cost of doing nothing is huge

The Healthcare & Social Assistance industry suffers more than 17,000 musculoskeletal injuries a year, according to Safe Work Australia (Australian Workers' Compensation Statistics, 2012–13). The median cost of a push/pull injury is \$9,700 with 6 weeks lost. With an annual incidence rate of 12.5 per 1000 employees suffering serious injuries related to injury & musculoskeletal disorders, the cost to a Healthcare facility can be enormous. And of course the personal cost to an injured worker can be devastating.

Known injury risk factors

High forces when manoeuvring wheeled equipment increase the risk of musculoskeletal disorders. Table 1 on the next page offers the best state of knowledge on pushing and pulling, which is based on the work of Snook and Ciriello*. Snook investigated a large number of tasks in which workers had been injured in order to establish the relationship between perceived risk and actual injury occurrence.

Snook's maximum acceptable forces are set out in Table 1, which describes how frequently a worker can push wheeled equipment based on the distance travelled and weight pushed. So, for example, a heavy trolley with 11 kg of sustained push effort can be pushed short distances (7.6 m) every 1 minute, but if you have moderate distances to travel (30.5 m) it is only safe to do this once every 8 hours, and very long distances (61 m+) are not acceptable.

These benchmarks for safe push/pull forces have been adopted as benchmarks within Australia's regulatory environment. But many Australian work places ask staff to push hospital beds or catering and linen trolleys with push effort well above 11 kg for distances and frequencies well above these published government guidelines.



Using a strain gauge to measure the force required to pull a hospital bed.

Reducing push/pull injuries is easy...

...if you work with the experts to redesign your work processes.

The *Hazardous Manual Tasks, Work Health & Safety Code of Practice*, and the related state government industry guideline publications can be so broad that they tell you what the problem is, but offer only vague solutions.

For example, WorkSafe Victoria in their publication *Injury Hotspots Health & Aged Care Services* directs “when pushing and pulling trolleys and wheelchairs, provide equipment that is fit for the purpose and maintained in accordance with manufacturer’s specifications”.

We can help you go from knowing what the problem is, to actually doing something to fix it. We offer actionable solutions with industry best-practice equipment.

The bottom line

Published government guidelines, developed from evidence-based analysis of injuries in the healthcare sector due to pushing and pulling mobile equipment, mandate that pushing a bed, linen cart or meal delivery system is a two-person job unless a motorised solution is utilised.

Complying with the *Hazardous Manual Tasks, Work Health and Safety Code of Practice* makes good business sense as well as being the right thing to do.

TABLE 1: ACCEPTABLE FREQUENCIES FOR SUSTAINED STRAIGHT LINE PUSHING OF WHEELED EQUIPMENT OVER VARIOUS DISTANCES, HANDLE HEIGHT 890 MM (SNOOK AND CIRIELLO 1991)

Distance	2.1 m	7.6 m	15.2 m	30.5 m	45.7 m	61 m
Sustained force	Frequency—75% of female workforce may push wheeled equipment over stated distance once every:					
6 kg or less	6 sec	15 sec	25 sec	1 min	1 min	2 min
7 kg	6 sec	15 sec	25 sec	1 min	1 min	30 min
8 kg	6 sec	15 sec	35 sec	1 min	2 min	8 hr
9 kg	12 sec	15 sec	1 min	2 min	30 min	8 hr
10 kg	12 sec	22 sec	2 min	30 min	8 hr	Not acceptable
11 kg	12 sec	1 min	5 min	8 hr	8 hr	Not acceptable
12 kg	1 min	5 min	8 hr	8 hr	8 hr	Not acceptable

* Source: *A guide to designing workplaces for safer handling of people for health, aged care, rehabilitation and disability facilities—3rd edition, September 2007—Public Sector and Community Services.*





General castors





L Series 30 KG



WHEELS

		Diameter x tread (mm)	Hub x bore (mm)	Max load (kg)
	LJP TPE, plain bearing, no thread guard	50 x 20	25 x 6	30
	LNN Hard nylon, plain bearing, no thread guard	50 x 20	25 x 6	30

FORKS

		Height (mm)	Turning radius (mm)
	LKP Plate with swivel	65	47
	LKPBR Plate with swivel and wheel brake	65	57
	LKF Fixed plate, no swivel	65	-
	LKH Bolt hole swivel	65	47
	LKHBR Bolt hole swivel and wheel brake	65	57

ORDER CODES

Wheel code	Castor code
LJP50 Diameter: 50 mm	LJP50/LKP
	LJP50/LKPBR
	LJP50/LKF
	LJP50/LKH
	LJP50/LKHBR
LNN50 Diameter: 50 mm	LNN50/LKP
	LNN50/LKPBR
	LNN50/LKF
	LNN50/LKH
	LNN50/LKHBR

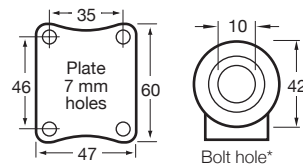

* Grip-neck pintles also available (see page 59).

Twin Series 40 KG



CASTOR OPTIONS

-  **TW50P**
Plate with swivel

-  **TW50PBR**
Plate with swivel and wheel brake

-  **TW5038**
Threaded 3/8 pintle

-  **TW5038BR**
Threaded 3/8 pintle with wheel brake

-  **TW50CJ**
Friction stem

Mount (mm)

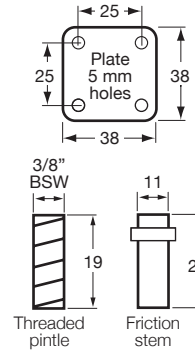

ORDER CODES

Diameter (mm)	Height (mm)	Turning radius (mm)	Max load (kg)	Castor code
50	61	46	40	TW50P
50	61	60	40	TW50PBR
50	61	46	40	TW5038
50	61	60	40	TW5038BR
50	61	46	40	TW50CJ

N Series 90 KG



CASTOR OPTIONS

-  **NNN40/NZP**
White nylon wheel in plate, with swivel

-  **NNN40/NZPBR**
White nylon wheel in plate, with swivel and wheel brake

Max load (kg)

Mount (mm)

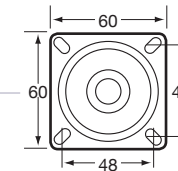





ORDER CODES

Diameter x tread (mm)	Hub x bore (mm)	Height (mm)	Turning radius (mm)	Castor code
40 x 44	53 x 6	62	40	NNN40/NZP
40 x 44	53 x 6	62	71	NNN40/NZPBR







K Series 100 KG

WHEELS

		Diameter x tread (mm)	Hub x bore (mm)	Max load (kg)
	KJQ*	65 x 23	30 x 8	50
	TPE, precision ball bearing, thread guard	75 x 23	30 x 8	50
		100 x 23	30 x 8	50
	KNN	65 x 23	30 x 8	50
	Hard nylon, plain bearing, no thread guard	75 x 23	30 x 8	65
		100 x 23	30 x 8	70
	KSA	65 x 23	30 x 12	50
	Grey rubber, flat profile, plain bearing, optional thread guard ¹	75 x 23	30 x 12	50
		100 x 23	30 x 12	50
	KUQ*	75 x 23	30 x 8	100
	Polyurethane, precision bearing, optional thread guard ¹	100 x 23	30 x 8	100

FORKS

		Wheel Diameter	Height (mm)	Turning radius (mm)
	KZP	65	96	63
	Plate with swivel	75	104	69
		100	131	82
	KZPTB	65	96	89
	Plate with swivel and total brake	75	104	89
		100	131	89
	KZF	65	96	-
	Fixed plate, no swivel	75	104	-
		100	131	-
	KZH	65	96	63
	Bolt hole swivel	75	104	69
		100	131	82
	KZHTB	65	96	89
	Bolt hole swivel and total brake	75	104	89
		100	131	89

ORDER CODES

Wheel code	Fork code	Castor code ²
KJQ65G Diameter: 65 mm	K65ZP	KJQ65G/KZP
	K65ZPTB	KJQ65G/KZPTB
	K65ZF	KJQ65G/KZF
	K65ZH	KJQ65G/KZH
	K65ZHTB	KJQ65G/KZHTB
KJQ75G Diameter: 75 mm	K75ZP	KJQ75G/KZP
	K75ZPTB	KJQ75G/KZPTB
	K75ZF	KJQ75G/KZF
	K75ZH	KJQ75G/KZH
	K75ZHTB	KJQ75G/KZHTB
KJQ100G Diameter: 100 mm	K100ZP	KJQ100G/KZP
	K100ZPTB	KJQ100G/KZPTB
	K100ZF	KJQ100G/KZF
	K100ZH	KJQ100G/KZH
	K100ZHTB	KJQ100G/KZHTB
KNN65 Diameter: 65 mm	K65ZP	KNN65/KZP
	K65ZPTB	KNN65/KZPTB
	K65ZF	KNN65/KZF
	K65ZH	KNN65/KZH
	K65ZHTB	KNN65/KZHTB
KNN75 Diameter: 75 mm	K75ZP	KNN75/KZP
	K75ZPTB	KNN75/KZPTB
	K75ZF	KNN75/KZF
	K75ZH	KNN75/KZH
	K75ZHTB	KNN75/KZHTB

Wheel code	Fork code	Castor code ²
KNN100 Diameter: 100 mm	K100ZP	KNN100/KZP
	K100ZPTB	KNN100/KZPTB
	K100ZF	KNN100/KZF
	K100ZH	KNN100/KZH
	K100ZHTB	KNN100/KZHTB
KSA65 Diameter: 65 mm	K65ZP	KSA65/KZP
	K65ZPTB	KSA65/KZPTB
	K65ZF	KSA65/KZF
	K65ZH	KSA65/KZH
	K65ZHTB	KSA65/KZHTB
KSA75¹ Diameter: 75 mm	K75ZP	KSA75/KZP
	K75ZPTB	KSA75/KZPTB
	K75ZF	KSA75/KZF
	K75ZH	KSA75/KZH
	K75ZHTB	KSA75/KZHTB
KSA100¹ Diameter: 100 mm	K100ZP	KSA100/KZP
	K100ZPTB	KSA100/KZPTB
	K100ZF	KSA100/KZF
	K100ZH	KSA100/KZH
	K100ZHTB	KSA100/KZHTB
KUQ75¹ Diameter: 75 mm	K75ZP	KUQ75/KZP
	K75ZPTB	KUQ75/KZPTB
	K75ZF	KUQ75/KZF
	K75ZH	KUQ75/KZH
	K75ZHTB	KUQ75/KZHTB
KUQ100¹ Diameter: 100 mm	K100ZP	KUQ100/KZP
	K100ZPTB	KUQ100/KZPTB
	K100ZF	KUQ100/KZF
	K100ZH	KUQ100/KZH
	K100ZHTB	KUQ100/KZHTB

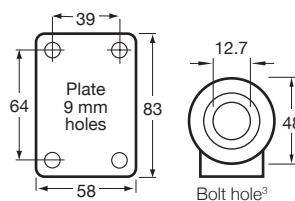

* Wheels also available with plain bearings—KJA, KUA.
Note that plain bearing bore is 12 mm.

¹ For optional thread guards, add **G** at the end of wheel code.

² For optional Chicago screw axles, add **C** at the end of castor code.









³ Bushes available to reduce bolt hole to 8 mm, 3/8" and 10 mm.
Grip-neck pintles also available (see page 59).



M Series 200 KG



WHEELS







	Diameter x tread (mm)	Hub x bore (mm)	Max load (kg)	
	CBQ	75 x 33	40 x 8	85
	Blue high resilience elastomer, precision bearing, thread guard	100 x 33	40 x 8	100
		125 x 33	40 x 8	100
	MBQ	100 x 32	40 x 8	140
	Blue high resilience elastomer, precision bearing, thread guard	125 x 32	40 x 8	150
	MNN*	75 x 32	40 x 8	150
	Hard nylon, plain bearing, no thread guard	100 x 32	40 x 8	150
		125 x 32	40 x 8	150
	DNQ*	125 x 32	40 x 8	200
	Hard nylon, precision bearing, no thread guard			
	STQ	75 x 32	40 x 8	100
	Grey energy absorbent elastomer, round profile, precision bearing, thread guard	100 x 32	40 x 8	100
		125 x 32	40 x 8	100
	MJQ¹	75 x 32	40 x 8	85
	TPE, precision bearing, thread guard	100 x 32	40 x 8	85
	MSQ²	100 x 34	40 x 8	140
	Grey rubber, flat profile, precision bearing, thread guard	125 x 34	40 x 8	150
	QUQ²	75 x 32	40 x 8	200
	Polyurethane, precision bearing, thread guard	100 x 32	40 x 8	200
		125 x 32	40 x 8	200

* Wheels also available in white—DNQ125W, MNN...W.

¹ Wheel also available in anti-static—MAQ, or plain bearing—MJA.

² Wheel also available with plain bearing—MSA, QUA.

FORKS

	Wheel Diameter	Height (mm)	Turning radius (mm)	
	MZP	75	106	71
	Plate with swivel	100	135	91
		125	161	103
	MZPTB	75	106	118
	Plate with swivel and total brake	100	135	128
		125	161	128
	MZPDL	75	106	118
	Plate with swivel and direction lock	100	135	128
		125	161	128
	MZF	75	106	-
	Fixed plate, no swivel	100	135	-
		125	161	-
	MZH	75	106	71
	Bolt hole swivel	100	135	91
		125	161	103
	MZHTB	75	106	118
	Bolt hole swivel and total brake	100	135	128
		125	161	128
	MZHDL	75	106	118
	Bolt hole swivel and direction lock	100	135	128
		125	161	128

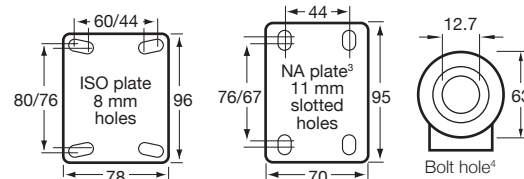

³ North American plate. Add **N** at the end of fork code to purchase (e.g. CBQ75G/MZPNTB).

⁴ Bushes available to reduce bolt hole to 8 mm, 3/8" and 10 mm. Grip-neck pintles also available (see page 59).

ORDER CODES

Wheel code	Fork code	Castor code	
CBQ75G Diameter: 75 mm	M75ZP	CBQ75G/MZP	
	M75ZPTB	CBQ75G/MZPTB	
	M75ZPDL	CBQ75G/MZPDL	
	M75ZF	CBQ75G/MZF	
	M75ZH	CBQ75G/MZH	
	M75ZHTB	CBQ75G/MZHTB	
	M75ZHDL	CBQ75G/MZHDL	
	CBQ100G Diameter: 100 mm	M100ZP	CBQ100G/MZP
		M100ZPTB	CBQ100G/MZPTB
		M100ZPDL	CBQ100G/MZPDL
M100ZF		CBQ100G/MZF	
M100ZH		CBQ100G/MZH	
	M100ZHTB	CBQ100G/MZHTB	
	M100ZHDL	CBQ100G/MZHDL	
	CBQ125G Diameter: 125 mm	M125ZP	CBQ125G/MZP
		M125ZPTB	CBQ125G/MZPTB
		M125ZPDL	CBQ125G/MZPDL
M125ZF		CBQ125G/MZF	
M125ZH		CBQ125G/MZH	
	M125ZHTB	CBQ125G/MZHTB	
	M125ZHDL	CBQ125G/MZHDL	
	DNQ125 Diameter: 125 mm	M125ZP	DNQ125/MZP
		M125ZPTB	DNQ125/MZPTB
		M125ZPDL	DNQ125/MZPDL
M125ZF		DNQ125/MZF	
M125ZH		DNQ125/MZH	
	M125ZHTB	DNQ125/MZHTB	
	M125ZHDL	DNQ125/MZHDL	
	MBQ100G Diameter: 100 mm	M100ZP	MBQ100G/MZP
		M100ZPTB	MBQ100G/MZPTB
		M100ZPDL	MBQ100G/MZPDL
M100ZF		MBQ100G/MZF	
M100ZH		MBQ100G/MZH	
	M100ZHTB	MBQ100G/MZHTB	
	M100ZHDL	MBQ100G/MZHDL	

Wheel code	Fork code	Castor code
MBQ125G Diameter: 125 mm	M125ZP	MBQ125G/MZP
	M125ZPTB	MBQ125G/MZPTB
	M125ZPDL	MBQ125G/MZPDL
	M125ZF	MBQ125G/MZF
	M125ZH	MBQ125G/MZH
	M125ZHTB	MBQ125G/MZHTB
M125ZHDL	MBQ125G/MZHDL	
MJQ75G Diameter: 75 mm	M75ZP	MJQ75G/MZP
	M75ZPTB	MJQ75G/MZPTB
	M75ZPDL	MJQ75G/MZPDL
	M75ZF	MJQ75G/MZF
	M75ZH	MJQ75G/MZH
	M75ZHTB	MJQ75G/MZHTB
M75ZHDL	MJQ75G/MZHDL	
MJQ100G Diameter: 100 mm	M100ZP	MJQ100G/MZP
	M100ZPTB	MJQ100G/MZPTB
	M100ZPDL	MJQ100G/MZPDL
	M100ZF	MJQ100G/MZF
	M100ZH	MJQ100G/MZH
	M100ZHTB	MJQ100G/MZHTB
M100ZHDL	MJQ100G/MZHDL	
MJQ125G Diameter: 125 mm	M125ZP	MJQ125G/MZP
	M125ZPTB	MJQ125G/MZPTB
	M125ZPDL	MJQ125G/MZPDL
	M125ZF	MJQ125G/MZF
	M125ZH	MJQ125G/MZH
	M125ZHTB	MJQ125G/MZHTB
M125ZHDL	MJQ125G/MZHDL	
MNN75 Diameter: 75 mm	M75ZP	MNN75/MZP
	M75ZPTB	MNN75/MZPTB
	M75ZPDL	MNN75/MZPDL
	M75ZF	MNN75/MZF
	M75ZH	MNN75/MZH
	M75ZHTB	MNN75/MZHTB
M75ZHDL	MNN75/MZHDL	

Wheel code	Fork code	Castor code
MNN100 Diameter: 100 mm	M100ZP	MNN100/MZP
	M100ZPTB	MNN100/MZPTB
	M100ZPDL	MNN100/MZPDL
	M100ZF	MNN100/MZF
	M100ZH	MNN100/MZH
	M100ZHTB	MNN100/MZHTB
M100ZHDL	MNN100/MZHDL	
MNN125 Diameter: 125 mm	M125ZP	MNN125/MZP
	M125ZPTB	MNN125/MZPTB
	M125ZPDL	MNN125/MZPDL
	M125ZF	MNN125/MZF
	M125ZH	MNN125/MZH
	M125ZHTB	MNN125/MZHTB
M125ZHDL	MNN125/MZHDL	
MSQ100G Diameter: 100 mm	M100ZP	MSQ100G/MZP
	M100ZPTB	MSQ100G/MZPTB
	M100ZPDL	MSQ100G/MZPDL
	M100ZF	MSQ100G/MZF
	M100ZH	MSQ100G/MZH
	M100ZHTB	MSQ100G/MZHTB
M100ZHDL	MSQ100G/MZHDL	
MSQ125G Diameter: 125 mm	M125ZP	MSQ125G/MZP
	M125ZPTB	MSQ125G/MZPTB
	M125ZPDL	MSQ125G/MZPDL
	M125ZF	MSQ125G/MZF
	M125ZH	MSQ125G/MZH
	M125ZHTB	MSQ125G/MZHTB
M125ZHDL	MSQ125G/MZHDL	
QUQ75G Diameter: 75 mm	M75ZP	QUQ75G/MZP
	M75ZPTB	QUQ75G/MZPTB
	M75ZPDL	QUQ75G/MZPDL
	M75ZF	QUQ75G/MZF
	M75ZH	QUQ75G/MZH
	M75ZHTB	QUQ75G/MZHTB
M75ZHDL	QUQ75G/MZHDL	

Wheel code	Fork code	Castor code
QUQ100G Diameter: 100 mm	M100ZP	QUQ100G/MZP
	M100ZPTB	QUQ100G/MZPTB
	M100ZPDL	QUQ100G/MZPDL
	M100ZF	QUQ100G/MZF
	M100ZH	QUQ100G/MZH
	M100ZHTB	QUQ100G/MZHTB
M100ZHDL	QUQ100G/MZHDL	
QUQ125G Diameter: 125 mm	M125ZP	QUQ125G/MZP
	M125ZPTB	QUQ125G/MZPTB
	M125ZPDL	QUQ125G/MZPDL
	M125ZF	QUQ125G/MZF
	M125ZH	QUQ125G/MZH
	M125ZHTB	QUQ125G/MZHTB
M125ZHDL	QUQ125G/MZHDL	
STQ75G Diameter: 75 mm	M75ZP	STQ75G/MZP
	M75ZPTB	STQ75G/MZPTB
	M75ZPDL	STQ75G/MZPDL
	M75ZF	STQ75G/MZF
	M75ZH	STQ75G/MZH
	M75ZHTB	STQ75G/MZHTB
M75ZHDL	STQ75G/MZHDL	
STQ100G Diameter: 100 mm	M100ZP	STQ100G/MZP
	M100ZPTB	STQ100G/MZPTB
	M100ZPDL	STQ100G/MZPDL
	M100ZF	STQ100G/MZF
	M100ZH	STQ100G/MZH
	M100ZHTB	STQ100G/MZHTB
M100ZHDL	STQ100G/MZHDL	
STQ125G Diameter: 125 mm	M125ZP	STQ125G/MZP
	M125ZPTB	STQ125G/MZPTB
	M125ZPDL	STQ125G/MZPDL
	M125ZF	STQ125G/MZF
	M125ZH	STQ125G/MZH
	M125ZHTB	STQ125G/MZHTB
M125ZHDL	STQ125G/MZHDL	



Big M Series 200 KG









WHEEL

	Diameter x tread (mm)	Hub x bore (mm)	Max load (kg)
 QTQ*	150 x 34	40 x 8	200
Grey energy absorbent elastomer, round profile, precision bearing, thread guard	175 x 34	40 x 8	200

* Wheel also available with plain bearing – QTA.

FORKS

	Wheel Diameter	Height (mm)	Turning radius (mm)
 MZP Plate with swivel	150 175	187 214	130 145
 MZPTB Plate with swivel and total brake	150 175	187 214	153 153
 MZPDL Plate with swivel and direction lock	150 175	187 214	153 153
 MZFB Fixed plate, no swivel	150	187	-
 MZH Bolt hole swivel	150 175	187 214	130 145
 MZHTB Bolt hole swivel and total brake	150 175	187 214	153 153
 MZHDL Bolt hole swivel and direction lock	150 175	187 214	153 153

ORDER CODES

Wheel code	Fork code	Castor code
QTQ150G Diameter: 150 mm	M150ZP	QTQ150G/MZP
	M150ZPTB	QTQ150G/MZPTB
	M150ZPDL	QTQ150G/MZPDL
	M150ZF	QTQ150G/MZF
	M150ZH	QTQ150G/MZH
	M150ZHTB	QTQ150G/MZHTB
QTQ175G Diameter: 175 mm	M150ZHDL	QTQ150G/MZHDL
	M175ZP	QTQ175G/MZP
	M175ZPTB	QTQ175G/MZPTB
	M175ZPDL	QTQ175G/MZPDL
	M175ZH	QTQ175G/MZH
	M175ZHTB	QTQ175G/MZHTB
	M175ZHDL	QTQ175G/MZHDL

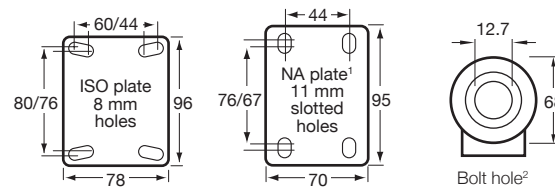

¹ North American plate. Add **N** at the end of fork code to purchase (e.g. QTQ150G/MZPNTB).

² Bushes available to reduce bolt hole to 8 mm, 3/8" and 10 mm.

Customising K and M Series

Colourway

All castors come in a standard colourway. However, different colourways are also available on the K and M Series castors.

To specify a colourway, add the relevant colourway code to the end of the castor order code (e.g. KJA75G/KZHTBR).

Chicago Screw

In addition to the colourway, the standard nut and bolt axle can be replaced with a Chicago Screw (domed head) axle by adding a 'C' to the end of the code.



K SERIES COLOURWAY



K Series castor shown in standard colourway

Standard



Red (R)



Grey (G)



M SERIES COLOURWAY



Big M Series castor shown in standard colourway

Standard



Black (B)



Grey (G)



COLOURWAY AND AXLE CODES*



Standard colourway with standard nut and bolt axle
KJA75G/KZHTB



Standard colourway with Chicago Screw axle
KJA75G/KZHTBC



Red colourway with standard nut and bolt axle
KJA75G/KZHTBR



Red colourway with Chicago Screw axle
KJA75G/KZHTBRC



Grey colourway with standard nut and bolt axle
KJA75G/KZHTBG



Grey colourway with Chicago Screw axle
KJA75G/KZHTBGC

* Colourway and axle options shown on K Series castors. These options can also be applied to M and Big M Series castors.



J Series 300 KG

WHEELS

		Diameter x tread (mm)	Hub x bore (mm)	Max load (kg)
	JBR*	100 x 32	45 x 10	150
	Blue high resilience elastomer, roller bearing, optional thread guard	125 x 32	45 x 10	180
	JCR*	100 x 38	45 x 10	230
	Cast iron, roller bearing, no thread guard			
	JNR*	100 x 35	45 x 10	300
	Hard nylon, roller bearing, optional thread guard	125 x 35	45 x 10	300
	JUR*	100 x 32	45 x 10	300
	Polyurethane, roller bearing, optional thread guard	125 x 38	45 x 10	300

ORDER CODES

Wheel code	Fork code	Castor code
JBR100¹ Diameter: 100 mm	J100ZP	JBR100/JZP
	J100ZPTB	JBR100/JZPTB
	J100ZF	JBR100/JZF
	J100ZH	JBR100/JZH
	J100ZHTB	JBR100/JZHTB
JBR125¹ Diameter: 125 mm	J125ZP	JBR125/JZP
	J125ZPTB	JBR125/JZPTB
	J125ZF	JBR125/JZF
	J125ZH	JBR125/JZH
	J125ZHTB	JBR125/JZHTB
JCR100 Diameter: 100 mm	J100ZP	JCR100/JZP
	J100ZF	JCR100/JZF
	J100ZH	JCR100/JZH

Wheel code	Fork code	Castor code
JNR100¹ Diameter: 100 mm	J100ZP	JNR100/JZP
	J100ZPTB	JNR100/JZPTB
	J100ZF	JNR100/JZF
	J100ZH	JNR100/JZH
	J100ZHTB	JNR100/JZHTB
JNR125¹ Diameter: 125 mm	J125ZP	JNR125/JZP
	J125ZPTB	JNR125/JZPTB
	J125ZF	JNR125/JZF
	J125ZH	JNR125/JZH
	J125ZHTB	JNR125/JZHTB
JUR100¹ Diameter: 100 mm	J100ZP	JUR100/JZP
	J100ZPTB	JUR100/JZPTB
	J100ZF	JUR100/JZF
	J100ZH	JUR100/JZH
	J100ZHTB	JUR100/JZHTB
JUR125¹ Diameter: 125 mm	J125ZP	JUR125/JZP
	J125ZPTB	JUR125/JZPTB
	J125ZF	JUR125/JZF
	J125ZH	JUR125/JZH
	J125ZHTB	JUR125/JZHTB

FORKS

	Wheel Diameter	Height (mm)	Turning radius (mm)
	JZP	100	129
	Plate with swivel	125	155
	JZPTB	100	129
	Plate with swivel and total brake	125	155
	JZF	100	129
	Fixed plate, no swivel	125	155
	JZH	100	129
	Bolt hole swivel	125	155
	JZHTB	100	129
	Bolt hole swivel and total brake	125	155

Mounts (mm)

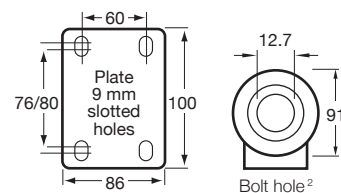

* Wheels also available with plain bearings—JBA, JCI, JNN, JUA.











¹ For optional thread guards, add **G** at the end of wheel code.

² Bushes available to reduce bolt hole to 8 mm, 3/8" and 10 mm. Also available with a 16 mm bolt hole fork as a custom order.









Y Series 180 KG

WHEELS

	Diameter x tread (mm)	Max load (kg)
Puncture proof		
 YPRIB200 Grey polyurethane foam-filled neoprene tyre, steel rim, precision bearing	200 x 50	50
 YPLUG250 Black polyurethane foam-filled neoprene tyre, steel rim, deep groove ball bearing	220 x 54	75
 YPSTR350 Black polyurethane foam-filled rubber tyre, steel rim, precision bearing	265 x 70	100
Steel centred		
 YSLUG250 Black neoprene tyre, steel rim, deep groove ball bearing	220 x 54	120
 YSSTR350 Black neoprene tyre, steel rim, precision bearing	265 x 70	180
Plastic centred		
 YRIB200 Grey neoprene tyre, plastic rim, precision bearing	200 x 50	75
 YLUG250 Black neoprene tyre, plastic rim, deep groove ball bearing	220 x 54	100
 YLG250 Grey neoprene tyre, plastic rim, deep groove ball bearing	220 x 54	100
 YSTR350 Black neoprene tyre, plastic rim, precision bearing	265 x 70	140
 YZGG350 Grey neoprene tyre, plastic rim, precision bearing	265 x 70	140

FORK OPTIONS

	Nominal size	Height (mm)	Turning radius (mm)
Puncture proof			
 YZP Plate with swivel	200	238	155
	250	250	200
	350	320	223
 YZF Fixed plate, no swivel	200	238	-
	250	250	-
	350	320	-
Steel centred			
 YZP Plate with swivel	250	250	200
	350	320	223
 YZF Fixed plate, no swivel	250	250	-
	350	320	-
Plastic centred			
 YZP Plate with swivel	200	238	155
	250	250	200
	350	320	223
 YZF Fixed plate, no swivel	200	238	-
	250	250	-
	350	320	-

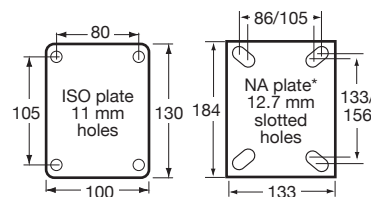

* North American plate. Add **N** at the end of fork code to purchase (e.g. YRIB200/YZPN).





ORDER CODES

Wheel code	Fork code	Castor code
YPRIB200	Y200ZP	YPRIB200/YZP
	Y200ZF	YPRIB200/YZF
YPLGG250	Y250ZP	YPLGG250/YZP
	Y250ZF	YPLGG250/YZF
YPLUG250	Y250ZP	YPLUG250/YZP
	Y250ZF	YPLUG250/YZF
YPSTR350	Y350ZP	YPSTR350/YZP
	Y350ZF	YPSTR350/YZF
YSLUG250	Y250ZP	YSLUG250/YZP
	Y250ZF	YSLUG250/YZF
YSSTR350	Y350ZP	YSSTR350/YZP
	Y350ZF	YSSTR350/YZF
YRIB200	Y200ZP	YRIB200/YZP
	Y200ZF	YRIB200/YZF
YLG250	Y250ZP	YLG250/YZP
	Y250ZF	YLG250/YZF
YLUG250	Y250ZP	YLUG250/YZP
	Y250ZF	YLUG250/YZF
YSTR350	Y350ZP	YSTR350/YZP
	Y350ZF	YSTR350/YZF
YZGG350	Y350ZP	YZGG350/YZP
	Y350ZF	YZGG350/YZF







O Series 500 KG

WHEELS

		Diameter x tread (mm)	Hub x bore (mm)	Max load (kg)
	HBR*	150 x 40	60 x 12.7	230
	Blue high resilience elastomer, roller bearing, optional thread guard	200 x 50	60 x 12.7	250
	HSR*	200 x 50	60 x 12.7	250
	Grey high resilience elastomer, roller bearing, optional thread guard			
	HUR*	100 x 40	60 x 12.7	300
	Polyurethane on nylon, roller bearing, optional thread guard (150 mm wheel only)	125 x 40	60 x 12.7	350
		150 x 40	60 x 12.7	450
		200 x 48	60 x 12.7	500
	OBQ	100 x 50	60 x 12.7	300
	Blue high resilience elastomer, round profile, precision ball bearing, no thread guard	125 x 50	60 x 12.7	350
		150 x 50	60 x 12.7	400
		200 x 50	60 x 12.7	400
	ONR*	100 x 40	60 x 12.7	350
	Hard nylon, roller bearing, no thread guard	125 x 40	60 x 12.7	400
		150 x 40	60 x 12.7	450
		200 x 40	60 x 12.7	500

* Wheels also available with plain bearings – HBA, HSA, HUA, ONA.

FORKS

		Wheel Diameter	Height (mm)	Turning radius (mm)
	OZP	100	138	96
	Plate with swivel	125	162	109
		150	189	121
		200	239	152
	HZF	100	138	-
	Fixed plate, no swivel	125	162	-
		150	189	-
		200	239	-
	OZPTB	100	138	162
	Plate with swivel and total brake	125	162	180
		150	189	180
		200	239	195
	OZPDL	100	138	162
	Plate with swivel and direction lock	125	162	180
		150	189	180
		200	239	195

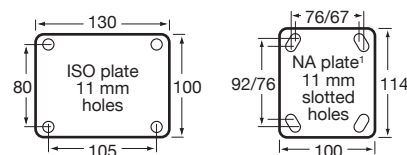

¹ North American plate. Add **N** at the end of fork code to purchase (e.g. HBR150/OZPNTB).

ORDER CODES

Wheel code	Fork code	Castor code
HBR150² Diameter: 150 mm	O150ZP	HBR150/OZP
	H150ZF	HBR150/HZF
	O150ZPTB	HBR150/OZPTB
	O150ZPDL	HBR150/OZPDL
HBR200² Diameter: 200 mm	O200ZP	HBR200/OZP
	H200ZF	HBR200/HZF
	O200ZPDL	HBR200/OZPDL
HSR200² Diameter: 200 mm	O200ZP	HSR200/OZP
	H200ZF	HSR200/HZF
	O200ZPDL	HSR200/OZPDL
HUR100 Diameter: 100 mm	O100ZP	HUR100/OZP
	H100ZF	HUR100/HZF
	O100ZPTB	HUR100/OZPTB
	O100ZPDL	HUR100/OZPDL
HUR125 Diameter: 125 mm	O125ZP	HUR125/OZP
	H125ZF	HUR125/HZF
	O125ZPTB	HUR125/OZPTB
	O125ZPDL	HUR125/OZPDL
HUR150² Diameter: 150 mm	O150ZP	HUR150/OZP
	H150ZF	HUR150/HZF
	O150ZPTB	HUR150/OZPTB
	O150ZPDL	HUR150/OZPDL
HUR200 Diameter: 200 mm	O200ZP	HUR200/OZP
	H200ZF	HUR200/HZF
	O200ZPTB	HUR200/OZPTB
	O200ZPDL	HUR200/OZPDL

² For optional thread guards, add **G** at the end of wheel code.







Wheel code	Fork code	Castor code
OBQ100 Diameter: 100 mm	O100ZP	OBQ100/OZP
	H100ZF	OBQ100/HZF
	O100ZPTB	OBQ100/OZPTB
	O100ZPDL	OBQ100/OZPDL
OBQ125 Diameter: 125 mm	O125ZP	OBQ125/OZP
	H125ZF	OBQ125/HZF
	O125ZPTB	OBQ125/OZPTB
OBQ150 Diameter: 150 mm	O150ZP	OBQ150/OZP
	H150ZF	OBQ150/HZF
	O150ZPTB	OBQ150/OZPTB
OBQ200 Diameter: 200 mm	O200ZP	OBQ200/OZP
	H200ZF	OBQ200/HZF
	O200ZPTB	OBQ200/OZPTB
	O200ZPDL	OBQ200/OZPDL

Wheel code	Fork code	Castor code
ONR100 Diameter: 100 mm	O100ZP	ONR100/OZP
	H100ZF	ONR100/HZF
	O100ZPTB	ONR100/OZPTB
	O100ZPDL	ONR100/OZPDL
ONR125 Diameter: 125 mm	O125ZP	ONR125/OZP
	H125ZF	ONR125/HZF
	O125ZPTB	ONR125/OZPTB
ONR150 Diameter: 150 mm	O150ZP	ONR150/OZP
	H150ZF	ONR150/HZF
	O150ZPTB	ONR150/OZPTB
ONR200 Diameter: 200 mm	O200ZP	ONR200/OZP
	H200ZF	ONR200/HZF
	O200ZPTB	ONR200/OZPTB
	O200ZPDL	ONR200/OZPDL







H Series 600 KG

WHEELS

	Diameter x tread (mm)	Hub x bore (mm)	Max load (kg)
 OBQ Blue high resilience elastomer, round profile, precision bearing, no thread guard	150 x 50	60 x 12.7	400
	200 x 50	60 x 12.7	400
 WCI Cast iron, plain bearing	150 x 50	60 x 12.7	400
 WNQ Hard Nylon, precision bearing, no thread guard	150 x 40	60 x 12.7	600
	200 x 40	60 x 12.7	600
 WUQ Polyurethane, precision bearing, no thread guard	150 x 40	60 x 12.7	600
	200 x 40	60 x 12.7	600

FORKS

	Wheel Diameter	Height (mm)	Turning radius (mm)
 HZP Plate with swivel	150	189	121
	200	239	155
 HZF Fixed plate, no swivel	150	189	-
	200	239	-
 HZPTB Plate with swivel and total brake	150	189	165
	200	239	165
 HZPDL Plate with swivel and direction lock	150	189	165
	200	239	165

ORDER CODES



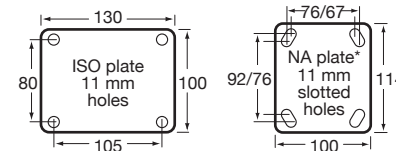

Wheel code	Fork code	Castor code
OBQ150 Diameter: 150 mm	H150ZP	OBQ150/HZP
	H150ZF	OBQ150/HZF
	H150ZPTB	OBQ150/HZPTB
OBQ200 Diameter: 200 mm	H200ZP	OBQ200/HZP
	H200ZF	OBQ200/HZF
	H200ZPTB	OBQ200/HZPTB
WCI150 Diameter: 150 mm	H150ZP	WCI150/HZP
	H150ZF	WCI150/HZF
	H150ZPDL	WCI150/HZPDL
WNQ150 Diameter: 150 mm	H150ZP	WNQ150/HZP
	H150ZF	WNQ150/HZF
	H150ZPTB	WNQ150/HZPTB
	H150ZPDL	WNQ150/HZPDL
WNQ200 Diameter: 200 mm	H200ZP	WNQ200/HZP
	H200ZF	WNQ200/HZF
	H200ZPTB	WNQ200/HZPTB
	H200ZPDL	WNQ200/HZPDL
WUQ150 Diameter: 150 mm	H150ZP	WUQ150/HZP
	H150ZF	WUQ150/HZF
	H150ZPTB	WUQ150/HZPTB
	H150ZPDL	WUQ150/HZPDL
	H200ZPDL	WUQ200/HZPDL
WUQ200 Diameter: 200 mm	H200ZP	WUQ200/HZP
	H200ZF	WUQ200/HZF
	H200ZPTB	WUQ200/HZPTB
	H200ZPDL	WUQ200/HZPDL



* North American plate. Add **N** at the end of fork code to purchase (e.g. OBQ150/HZPNTB).

SCAFFOLD CASTORS

	Diameter x tread (mm)	Hub x bore (mm)	Max load (kg)
 HUR¹ Polyurethane on nylon, roller bearing, optional thread guard (150 mm wheel only)	150 x 40	60 x 12.7	360
	200 x 48	60 x 12.7	500

Fittings	Castor	Max load (kg)	Fitting code
 51 mm socket mount to fit over tubes	HUR150/HZHTB¹	360	SC08
	HUR200/HZHTB	500	SC13
 ISO plate (130 x 100 mm)	HUR150/HZHTB¹	360	SC61
	HUR200/HZHTB	500	SC18
 38 mm solid stem with fully welded cup	HUR150/HZHTB¹	360	SC62
	HUR200/HZHTB	500	SC15
 38 mm stem mount to fit into tubes	HUR150/HZHTB¹	360	SC30
	HUR200/HZHTB	500	SC11

¹ For optional thread guard, add **G** at the end of wheel code.

Features that ensure scaffold castors satisfy OH&S requirements and Australian Standards:

- Castors are branded with maker's name and safe working load
- Supplied with a test certificate validating compliance to Australian Standards (important for risk management documentation)
- The static collapse load exceeds 3 times the working load
- Wheels 150 mm and 200 mm diameter to safely pass over obstacles without snagging and causing scaffold to tip
- The stem of the castor is 150 mm long, with not more than 3mm of clearance to tube
- An effective wheel/swivel brake is fitted to ensure maximum stability



Waste Bin Series 400 KG



WHEELS

		Diameter x tread (mm)	Hub x bore (mm)	Max load (kg)
	HCI Cast iron, plain bearing, no thread guard	150 x 50	60 x 20	500

FORKS

		Wheel Diameter	Height (mm)	Turning radius (mm)
	WZP Plate with swivel	150	194	130
	WZF Fixed plate, no swivel	150	194	-
	WZPTB Plate with swivel and total brake	150	194	176

ORDER CODES

Wheel code	Fork code	Castor code
HCI150	W150ZP	HCI150/WZP
Diameter: 150 mm	W150ZF	HCI150/WZF
	W150ZPTB	HCI150/WZPTB
Sets—2 x Fixed plate castors, 2 x Plate with swivel		
HC150 castors		SETDUMPERHC150



Brake not suitable for use on sloping ground.
Only use the total brake on flat ground.

This product is a resale item and not manufactured by Fallshaw.

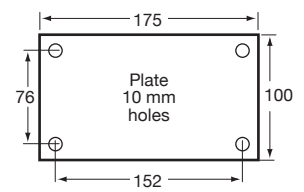









X Series 1000 KG



WHEELS

	Diameter x tread (mm)	Hub x bore (mm)	Max load (kg)	
	XCQ	102 x 48	62 x 12.7	450
	Cast iron, no thread guard	127 x 48	62 x 12.7	590
	152 x 48	62 x 12.7	630	
	203 x 50	62 x 12.7	820	
	XUQ	102 x 50	62 x 12.7	600
	Polyurethane on cast iron, precision bearing, no thread guard	127 x 50	62 x 12.7	800
	152 x 50	62 x 12.7	1000	
	203 x 50	62 x 12.7	1000	

FORKS

	Wheel Diameter	Height (mm)	Turning radius (mm)	
	XZP	100	143	95
	Plate with swivel	125	167	108
		150	193	137
		200	257	162
	XZF	100	143	-
	Fixed plate, no swivel	125	167	-
		150	193	-
		200	257	-
	XZPBR	100	143	219
	Plate with swivel and wheel brake	125	167	242
		150	193	266
		200	257	291
	XZPDL	100	143	95
	Plate with swivel and direction lock	125	167	108
		150	193	137
		200	257	162

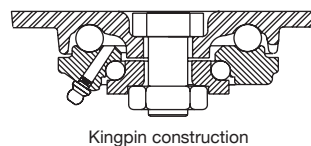
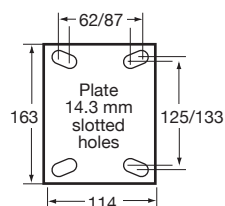



Kingpin construction

ORDER CODES

Wheel code	Fork code	Castor code
XCQ100 Diameter: 102 mm	X100ZP	XCQ100/XZP
	X100ZF	XCQ100/XZF
	X100ZPBR	XCQ100/XZPBR
	X100ZPDL	XCQ100/XZPDL
XCQ125 Diameter: 127 mm	X125ZP	XCQ125/XZP
	X125ZF	XCQ125/XZF
	X125ZPBR	XCQ125/XZPBR
	X125ZPDL	XCQ125/XZPDL
XCQ150 Diameter: 152 mm	X150ZP	XCQ150/XZP
	X150ZF	XCQ150/XZF
	X150ZPBR	XCQ150/XZPBR
	X150ZPDL	XCQ150/XZPDL
XCQ200 Diameter: 203 mm	X200ZP	XCQ200/XZP
	X200ZF	XCQ200/XZF
	X200ZPBR	XCQ200/XZPBR
	X200ZPDL	XCQ200/XZPDL
XUQ100 Diameter: 102 mm	X100ZP	XUQ100/XZP
	X100ZF	XUQ100/XZF
	X100ZPBR	XUQ100/XZPBR
	X100ZPDL	XUQ100/XZPDL
XUQ125 Diameter: 127 mm	X125ZP	XUQ125/XZP
	X125ZF	XUQ125/XZF
	X125ZPBR	XUQ125/XZPBR
	X125ZPDL	XUQ125/XZPDL
XUQ150 Diameter: 152 mm	X150ZP	XUQ150/XZP
	X150ZF	XUQ150/XZF
	X150ZPBR	XUQ150/XZPBR
	X150ZPDL	XUQ150/XZPDL
XUQ200 Diameter: 203 mm	X200ZP	XUQ200/XZP
	X200ZF	XUQ200/XZF
	X200ZPBR	XUQ200/XZPBR
	X200ZPDL	XUQ200/XZPDL



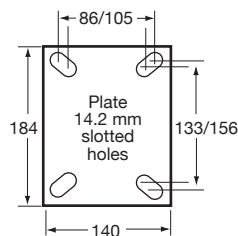

V Series 2450 KG

WHEELS

	Diameter x tread (mm)	Hub x bore (mm)	Max load (kg)
 VUQ Polyurethane on cast iron, precision bearing, no thread guard	203 x 75	89 x 20	2000
	254 x 75	89 x 20	2000
 VXQ High impact polymer, precision bearing, no thread guard	200 x 75	89 x 20	2450
	250 x 75	89 x 20	2450



FORKS

	Wheel Diameter	Height (mm)	Turning radius (mm)
 VZP Plate with swivel	200	267	165
	250	318	190
 VZF Fixed plate, no swivel	200	267	-
	250	318	-
 VZPBR Plate with swivel and wheel brake	200	267	317
	250	318	353
 VZPDL Plate with swivel and direction lock	200	267	165
	250	318	190

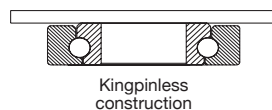

Kingpinless construction

ORDER CODES

Wheel code	Fork code	Castor code
VUQ200 Diameter: 203 mm	V200ZP	VUQ200/VZP
	V200ZF	VUQ200/VZF
	V200ZPBR	VUQ200/VZPBR
	V200ZPDL	VUQ200/VZPDL
VUQ250 Diameter: 254 mm	V250ZP	VUQ250/VZP
	V250ZF	VUQ250/VZF
	V250ZPBR	VUQ250/VZPBR
	V250ZPDL	VUQ250/VZPDL
VXQ200 Diameter: 203 mm	V200ZP	VXQ200/VZP
	V200ZF	VXQ200/VZF
	V200ZPBR	VXQ200/VZPBR
	V200ZPDL	VXQ200/VZPDL
VXQ250 Diameter: 254 mm	V250ZP	VXQ250/VZP
	V250ZF	VXQ250/VZF
	V250ZPBR	VXQ250/VZPBR
	V250ZPDL	VXQ250/VZPDL

A Series 3500 KG



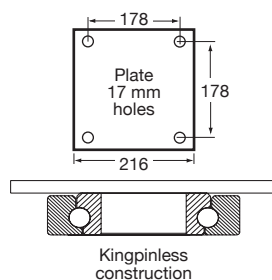

WHEELS

	Diameter x tread (mm)	Hub x bore (mm)	Max load (kg)
 AUQ Polyurethane on cast iron, precision bearing, no thread guard	200 x 102	109 x 30	3000
	250 x 102	109 x 30	3500



Kingpinless construction

FORKS

	Wheel Diameter	Height (mm)	Turning radius (mm)
 AZP Plate with swivel	200	279	172
	250	330	197
 AZF Fixed plate, no swivel	200	279	-
	250	330	-
 AZPBR Plate with swivel and wheel brake	200	279	317
	250	330	353
 AZPDL Plate with swivel and direction lock	200	279	172
	250	330	197

ORDER CODES

Wheel code	Castor code
AUQ200 Diameter: 200 mm	AUQ200/AZP
	AUQ200/AZF
	AUQ200/AZPBR
	AUQ200/AZPDL
AUQ250 Diameter: 250 mm	AUQ250/AZP
	AUQ250/AZF
	AUQ250/AZPBR
	AUQ250/AZPDL



Specialised castors



Automated Guided Vehicle (AGV) Cart Castors

Based on our M and O Series castors, the AGV Cart Castor is fitted with a self-aligning device that automatically aligns the castor with the AGV.

Fitted to your existing carts and trolleys, the AGV Cart Castor ensures that when an AGV picks up your cart, the castors stay in line with the AGV and do not swivel, thereby avoiding accidental contact with walls, pedestrians or the AGV itself.

If your organisation utilises AGVs only in pedestrian-free areas, and then switch to towing the cart with a Tug in pedestrian areas, our self-aligning direction lock castors ensure that your cart can be towed safely, without it swerving from side to side.

Minimum order quantities





Adding the self-aligning device requires piercing the fork. Mild steel versions can be made to order with minimum order quantities (200 pieces), however, as the self-aligning device cannot be added to an already-plated mild steel fork without damaging the corrosion protection, mild steel forks are not stocked and need to be made to order. No minimum order quantities apply to stainless steel versions.

AGV Cart Castors 500 KG

M SERIES WHEEL

	Diameter x tread (mm)	Hub x bore (mm)	Max load (kg)
 QTQ Grey energy absorbent elastomer, round profile, precision bearing, thread guard	150 x 34	40 x 8	200

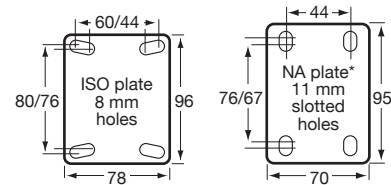

M SERIES FORKS

	Wheel Diameter	Height (mm)	Turning radius (mm)
 MZPSA Plate with swivel and self-aligning device	150	187	130
 MZP Fixed plate	150	187	-
 MZPTBSA Plate with swivel, total brake and self-aligning device	150	187	153
 MZPDLA Plate with swivel, direction lock and self-aligning device	150	187	153





* North American plate. Add **N** at the end of fork code to purchase (e.g. QTQ150/MZPNTBSA).

O SERIES WHEELS

	Diameter x tread (mm)	Hub x bore (mm)	Max load (kg)
 HUS* Polyurethane on nylon, roller bearing, optional thread guard (150 mm wheel only)	125 x 40 150 x 40 200 x 48	60 x 12.7 60 x 12.7 60 x 12.7	350 450 500
 OBC* Blue high resilience elastomer, round profile, precision ball bearing, no thread guard	125 x 50 150 x 50 200 x 50	60 x 12.7 60 x 12.7 60 x 12.7	350 400 400

O SERIES FORKS

	Wheel Diameter	Height (mm)	Turning radius (mm)
 OSPSA¹ Plate with swivel and self-aligning device	125 150 200	162 189 239	109 121 152
 HSF¹ Fixed plate, no swivel	125 150 200	162 189 239	- - -
 OSPTBSA¹ Plate with swivel and total brake	125 150 200	162 189 239	162 180 195
 OSPDLSA¹ Plate with swivel and direction lock	125 150 200	162 189 239	162 180 195

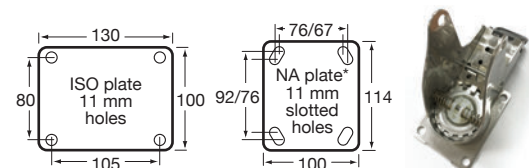

M SERIES ORDER CODES

Wheel code	Fork code	Castor code
QTQ150G	M150ZPSA	QTQ150G/MZPSA
Diameter: 150 mm	M150ZF	QTQ150G/MZF
	M150ZPTBSA	QTQ150G/MZPTBSA
	M150ZPDLA	QTQ150G/MZPDLA

O SERIES ORDER CODES

Wheel code	Fork code	Castor code	
HUS125* Diameter: 125 mm	O125SPSA	HUS125/OSPSA	
	H125SF	HUS125/HSF	
	O125SPTBSA	HUS125/OSPTBSA	
O125SPDLA	HUS125/OSPDLSA		
	HUS150* Diameter: 150 mm	O150SPSA	HUS150/OSPSA
		H150SF	HUS150/HSF
O150SPTBSA		HUS150/OSPTBSA	
O150SPDLA	HUS150/OSPDLSA		
	HUS200* Diameter: 200 mm	O200SPSA	HUS200/OSPSA
		H200SF	HUS200/HSF
O200SPTBSA		HUS200/OSPTBSA	
O200SPDLA	HUS200/OSPDLSA		
	OBC125* Diameter: 125 mm	O125SPSA	OBC125/OSPSA
		H125SF	OBC125/HSF
O125SPTBSA		OBC125/OSPTBSA	
O125SPDLA	OBC125/OSPDLSA		
	OBC150* Diameter: 150 mm	O150SPSA	OBC150/OSPSA
		H150SF	OBC150/HSF
O150SPTBSA		OBC150/OSPTBSA	
O150SPDLA	OBC150/OSPDLSA		
	OBC200* Diameter: 200 mm	O200SPSA	OBC200/OSPSA
		H200SF	OBC200/HSF
O200SPTBSA		OBC200/OSPTBSA	
O200SPDLA	OBC200/OSPDLSA		







* Wheels also available with mild steel bearings—HUR, OBQ.

¹ Forks also available in mild steel bearings—OZPSA, HZF, OZPTBSA, OZPDLA.



M Powder coat



WHEELS

		Diameter x tread (mm)	Hub x bore (mm)	Max load (kg)
	DNC White nylon, precision bearing, no thread guard	125 x 32	40 x 8	200
	MJC* TPE, precision bearing, thread guard	125 x 34	40 x 8	85
	MNN...W White nylon, plain bearing, no thread guard	125 x 32	40 x 8	150
	MSC¹ Grey rubber, flat profile, deep groove ball bearing, thread guard	125 x 34	40 x 8	150
	QTC¹ TPE, precision bearing, thread guard	150 x 34 175 x 34	40 x 8	150
	QUC¹ Polyurethane tyre on polypropylene centre, stainless steel precision bearing, thread guard	125 x 32	40 x 8	200

* Wheel also available in anti-static—MAC, or plain bearing—MJA.

¹ Wheels also available with plain bearings—MSA, QTA, QUA.

FORKS

		Wheel Diameter	Height (mm)	Turning radius (mm)
	MPH Bolt hole swivel	125	161	103
		150	187	130
		175	214	145
	MPHTB Bolt hole swivel and total brake	125	161	128
		150	187	153
		175	214	153
	MPHDL Bolt hole swivel and direction lock	125	161	128
		150	187	153
		175	214	153

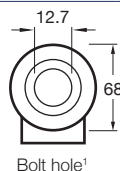

¹ Bushes available to reduce bolt hole to 8 mm, 3/8" and 10 mm.

BUFFER OPTIONS



-BUF 22
Suit -ER19 or -AR19

-BUF32
Suit 33 mm OD of hollow stem

-BUF 25
Suit -ER22 or -AR22

-BUF33.5
Suit 34 mm OD of hollow stem

-BUF28
Suit -ER28 or -AR28





ORDER CODES

Wheel code	Fork code	Castor code
DNC125 Diameter: 125 mm	M125PH	DNC125/MPH
	M125PHTB	DNC125/MPHTB
	M125PHDL	DNC125/MPHDL
MJC125G Diameter: 125 mm	M125PH	MJC125G/MPH
	M125PHTB	MJC125G/MPHTB
	M125PHDL	MJC125G/MPHDL
MNN125W Diameter: 125 mm	M125PH	MNN125W/MPH
	M125PHTB	MNN125W/MPHTB
	M125PHDL	MNN125W/MPHDL
MSC125G Diameter: 125 mm	M125PH	MSC125G/MPH
	M125PHTB	MSC125G/MPHTB
	M125PHDL	MSC125G/MPHDL
QTC150G Diameter: 150 mm	M150PH	QTC150G/MPH
	M150PHTB	QTC150G/MPHTB
	M150PHDL	QTC150G/MPHDL
QTC175G Diameter: 175 mm	M175PH	QTC175G/MPH
	M175PHTB	QTC175G/MPHTB
	M175PHDL	QTC175G/MPHDL
QUC125G Diameter: 125 mm	M125PH	QUC125G/MPH
	M125PHTB	QUC125G/MPHTB
	M125PHDL	QUC125G/MPHDL



M Stainless Steel







WHEELS

	Diameter x tread (mm)	Hub x bore (mm)	Max load (kg)
 DNC White nylon, precision bearing, no thread guard	125 x 32	40 x 8	200
 MJC* TPE, stainless steel deep groove ball bearing, thread guard	75 x 32 100 x 32 125 x 32	40 x 8 40 x 8 40 x 8	85 85 85
 MNN...WS White nylon, plain bearing, no thread guard	75 x 32 100 x 32 125 x 32	40 x 8 40 x 8 40 x 8	150 150 150
 MSC¹ Grey rubber, flat profile, deep groove ball bearing, thread guard	100 x 34 125 x 34	40 x 8 40 x 8	140 150
 QUC¹ Polyurethane tyre on nylon centre, stainless steel precision bearing, thread guard	75 x 32 100 x 32 125 x 32	40 x 8 40 x 8 40 x 8	200 200 200

* Wheel also available in anti-static—MAC, or plain bearing—MJA.

¹ Wheels also available with plain bearings—MSA, QUA.

FORKS¹

	Wheel Diameter	Height (mm)	Turning radius (mm)
 MSP Plate with swivel	75 100 125	106 135 161	71 91 103
 MSPTB Plate with swivel and total brake	75 100 125	106 135 161	118 128 128
 MSPDL Plate with swivel and direction lock	75 100 125	106 135 161	118 128 128
 MSF Fixed plate, no swivel	75 100 125	106 135 161	- - -
 MSH Bolt hole swivel	75 100 125	106 135 161	71 91 103
 MSHTB Bolt hole swivel and total brake	75 100 125	106 135 161	118 128 128
 MSHDL Bolt hole swivel and direction lock	75 100 125	106 135 161	118 128 128

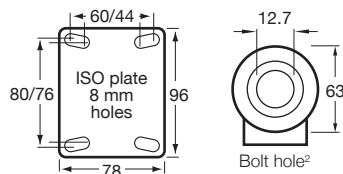

¹ To replace Chicago screw axles with regular hex bolt axles, add **-B** to the end of fork code.

² Bushes available to reduce bolt hole to 8 mm, 3/8" and 10 mm.

ORDER CODES

Wheel code	Fork code	Castor code
DNC125W Diameter: 125 mm	M125SP	DNC75W/MSP
	M125SPTB	DNC75W/MSPTB
	M125SPDL	DNC75W/MSPDL
	M125SF	DNC75W/MSF
	M125SH	DNC75W/MSH
MJC75G Diameter: 75 mm	M125SHTB	DNC75W/MSHTB
	M125SHDL	DNC75W/MSHDL
	M75SP	MJC75G/MSP
	M75SPTB	MJC75G/MSPTB
	M75SPDL	MJC75G/MSPDL
MJC100G Diameter: 100 mm	M75SF	MJC75G/MSF
	M75SH	MJC75G/MSH
	M75SHTB	MJC75G/MSHTB
	M75SHDL	MJC75G/MSHDL
	M100SP	MJC100G/MSP
MJC125G Diameter: 125 mm	M100SPTB	MJC100G/MSPTB
	M100SPDL	MJC100G/MSPDL
	M100SF	MJC100G/MSF
	M100SH	MJC100G/MSH
	M100SHTB	MJC100G/MSHTB
MJC125G Diameter: 125 mm	M100SHDL	MJC100G/MSHDL
	M125SP	MJC125G/MSP
	M125SPTB	MJC125G/MSPTB
	M125SPDL	MJC125G/MSPDL
	M125SF	MJC125G/MSF
	M125SH	MJC125G/MSH
	M125SHTB	MJC125G/MSHTB
	M125SHDL	MJC125G/MSHDL



Wheel code	Fork code	Castor code
MNN75WS Diameter: 75 mm	M75SP	MNN75WS/MSP
	M75SPTB	MNN75WS/MSPTB
	M75SPDL	MNN75WS/MSPDL
	M75SF	MNN75WS/MSF
	M75SH	MNN75WS/MSH
	M75SHTB	MNN75WS/MSHTB
	M75SHDL	MNN75WS/MSHDL
MNN100WS Diameter: 100 mm	M100SP	MNN100WS/MSP
	M100SPTB	MNN100WS/MSPTB
	M100SPDL	MNN100WS/MSPDL
	M100SF	MNN100WS/MSF
	M100SH	MNN100WS/MSH
	M100SHTB	MNN100WS/MSHTB
MNN125WS Diameter: 125 mm	M125SP	MNN125WS/MSP
	M125SPTB	MNN125WS/MSPTB
	M125SPDL	MNN125WS/MSPDL
	M125SF	MNN125WS/MSF
	M125SH	MNN125WS/MSH
	M125SHTB	MNN125WS/MSHTB
	M125SHDL	MNN125WS/MSHDL
MSC100G Diameter: 100 mm	M100SP	MSC100G/MSP
	M100SPTB	MSC100G/MSPTB
	M100SPDL	MSC100G/MSPDL
	M100SF	MSC100G/MSF
	M100SH	MSC100G/MSH
	M100SHTB	MSC100G/MSHTB
	M100SHDL	MSC100G/MSHDL





Wheel code	Fork code	Castor code
MSC125G Diameter: 125 mm	M125SP	MSC125G/MSP
	M125SPTB	MSC125G/MSPTB
	M125SPDL	MSC125G/MSPDL
	M125SF	MSC125G/MSF
	M125SH	MSC125G/MSH
	M125SHTB	MSC125G/MSHTB
	M125SHDL	MSC125G/MSHDL
QUC75G Diameter: 75 mm	M75SP	QUC75G/MSP
	M75SPTB	QUC75G/MSPTB
	M75SPDL	QUC75G/MSPDL
	M75SF	QUC75G/MSF
	M75SH	QUC75G/MSH
	M75SHTB	QUC75G/MSHTB
QUC100G Diameter: 100 mm	M100SP	QUC100G/MSP
	M100SPTB	QUC100G/MSPTB
	M100SPDL	QUC100G/MSPDL
	M100SF	QUC100G/MSF
	M100SH	QUC100G/MSH
	M100SHTB	QUC100G/MSHTB
	M100SHDL	QUC100G/MSHDL
QUC125G Diameter: 125 mm	M125SP	QUC125G/MSP
	M125SPTB	QUC125G/MSPTB
	M125SPDL	QUC125G/MSPDL
	M125SF	QUC125G/MSF
	M125SH	QUC125G/MSH
	M125SHTB	QUC125G/MSHTB
	M125SHDL	QUC125G/MSHDL



O Stainless Steel



WHEELS

	Diameter x tread (mm)	Hub x bore (mm)	Max load (kg)	
	HBS*			
	Blue high resilience elastomer, stainless steel roller bearing, no thread guard	150 x 40 200 x 50	60 x 12.7 60 x 12.7	230 250
	HSS*			
	Grey high resilience elastomer, stainless steel roller bearing, optional thread guard	200 x 50	60 x 12.7	250
	HUS*			
	Polyurethane on nylon, stainless steel roller bearing, no thread guard	100 x 40 125 x 40 150 x 40 200 x 48	60 x 12.7 60 x 12.7 60 x 12.7 60 x 12.7	300 350 450 450
	ONS...WS*			
	Hard nylon, stainless steel roller bearing, no thread guard	100 x 40 125 x 40 150 x 40 200 x 40	60 x 12.7 60 x 12.7 60 x 12.7 60 x 12.7	350 380 450 500

FORKS¹



OSP
Plate with swivel



HSF
Fixed plate, no swivel



OSPTB
Plate with swivel and total brake



OSPDL
Plate with swivel and direction lock

ORDER CODES

Wheel code	Fork code	Castor code	
HBS150	O150SP	HBS150/OSP	
Diameter: 150 mm	H150SF	HBS150/HSF	
	O150SPTB	HBS150/OSPTB	
	O150SPDL	HBS150/OSPDL	
	HBS200	O200SP	HBS200/OSP
Diameter: 200 mm	H200SF	HBS200/HSF	
	O200SPDL	HBS200/OSPDL	
	HSS200²	O200SP	HSS200/OSP
Diameter: 200 mm	H200SF	HSS200/HSF	
	O200SPDL	HSS200/OSPDL	
	HUS100	O100SP	HUS100/OSP
Diameter: 100 mm	H100SF	HUS100/HSF	
	O100SPTB	HUS100/OSPTB	
	O100SPDL	HUS100/OSPDL	
	HUS125	O125SP	HUS125/OSP
	Diameter: 125 mm	H125SF	HUS125/HSF
O125SPTB		HUS125/OSPTB	
O125SPDL		HUS125/OSPDL	
HUS150		O150SP	HUS150/OSP
Diameter: 150 mm	H150SF	HUS150/HSF	
	O150SPTB	HUS150/OSPTB	
	O150SPDL	HUS150/OSPDL	

Wheel code	Fork code	Castor code
HUS200	O200SP	HUS200/OSP
Diameter: 200 mm	H200SF	HUS200/HSF
	O200SPTB	HUS200/OSPTB
	O200SPDL	HUS200/OSPDL
	ONS100W	O100SP
Diameter: 100 mm	H100SF	ONS100W/HSF
	O100SPTB	ONS100W/OSPTB
	O100SPDL	ONS100W/OSPDL
	ONS125W	O125SP
Diameter: 125 mm	H125SF	ONS125W/HSF
	O125SPTB	ONS125W/OSPTB
	O125SPDL	ONS125W/OSPDL
ONS150W	O150SP	ONS150W/OSP
Diameter: 150 mm	H150SF	ONS150W/HSF
	O150SPTB	ONS150W/OSPTB
	O150SPDL	ONS150W/OSPDL
	ONS200W	O200SP
Diameter: 200 mm	H200SF	ONS200W/HSF
	O200SPTB	ONS200W/OSPTB
	O200SPDL	ONS200W/OSPDL

* Wheels also available with plain bearing—HBA, HSA, HUA...S, ONA...WS.

¹ See page 18 for O Series fork dimensions.

Also available with North American plate.



High and low temperature castors

Our standard wheels and castors have a temperature range of 5°C to 60°C. Within this range our products work normally for their full working life. For applications with temperatures outside this range we make specialised high temperature wheels designed to withstand temperatures of baking ovens, and low temperature wheels that can survive in freezing rooms.

High temperature use

As temperatures increase, wheels become weaker, which lower their load capacity and shorten their lifespan. It is important that you specify the temperature and type of application before ordering a castor, to ensure that the appropriate wheel type is selected. We make three different wheel types designed specifically for use in high temperature environments. These specialised wheels use standard lithium complex grease (STABUTHERM® GH 461) which has excellent water resistance (24 hrs at 90°C), bearing retention and long life.

Glass filled nylon (150–230°C)

The best choice for hospitality based applications such as ‘food baking’ ovens, glass filled nylon can withstand sustained high temperatures and is gentle and quiet on most floor surfaces. Fibreglass reinforced nylon wheels are the preferred wheel for extended periods of up to 210°C (assuming most of their life is spent outside the oven), and for short periods up to 230°C.

Phenolic (100–300°C)

Phenolic is more brittle than glass filled nylon and it has a shorter life cycle but can go up to very high temperatures. Phenolic is a good choice for light duty industrial applications with very high temperatures such as ovens used for curing paint. The load capacity decreases from 125 kg at 100°C to 40 kg at 300°C therefore it is very important to ensure that the load capacity of the trolley fits within the appropriate temperature and load capacity. Phenolic wheels (with special inorganic fillers and PTFE bushes) are preferred for extended periods up to 280°C assuming most of their life is spent outside the oven and for short periods up to 300°C. These have a thick cross section, but are more brittle than either nylon or ordinary grades of phenolic. **Please note that phenolic wheels are not suitable for medium duty applications or applications where wheels are subjected to impact such as when a trolley is rolled down steps.**

Cast iron (200–400°C)

The best choice for Industrial based applications such as ‘paint curing’ ovens and also for use in sustained high temperature environments, cast iron wheels can withstand extreme high temperatures as well as higher load capacities than all other wheel types. Cast iron wheels do not have bearings. They have a plain bore fitted with an axle spacer that is lubricated with high temperature grease. This grease can be used up to 230°C for long periods. For temperatures that exceed 230°C a more exotic grease is required. For sustained high temperature use, we offer a range of cast iron wheeled castors used with high temperature grease. Please note that cast iron is heavy, noisy and may damage concrete floors and other floor surfaces.

Low temperature use

Below 5°C you must specify temperature of use at the time of ordering. The standard grease we use in our castors is a lithium complex grease. This has excellent water resistance, bearing retention and long life. However below 5°C it begins to stiffen quickly, and will soon freeze the bearings so that neither the castor swivels nor the wheel bearings revolve. If specified at the time of ordering, we use a special aeronautical grease which is a synthetic oil with a microgel thickener. This is compounded for use down to -30°C, and will need to be refreshed every 6–12 months, but will continue to work effectively in chilling rooms, freezing stores and outdoor winter use in northern countries where ordinary greases would be useless.



As the temperature becomes lower, the softer rubber and polyurethane treads on our wheels become less elastic. For example, the polyurethane used on the ‘H’ series slowly stiffens from +20°C down to -20°C, but then rapidly stiffens until at -50°C, when it becomes brittle.

As temperature goes below 5°C, nylon can become brittle (particularly if it is kept for long periods in the very dry air in freezing rooms). At such times we recommend glass filled nylon reinforced wheels, which can be used down to -30°C.





M, J, O Series High/Low Temperature

M SERIES WHEELS

	Diameter x tread (mm)	Hub x bore (mm)	Max load (kg)
 DCI Cast iron, max load at 400°C, plain bearing, no thread guard	75 x 28	41 x 12	100
 MHH Glass reinforced nylon, lighter hub, max load at 150°C, plain bearing, no thread guard	100 x 32	41 x 12	80
Max loads at temperature (kg)			
	150°C 80	210°C 60	
	180°C 70	230°C 50*	
 MKT High temperature phenolic, max load at 100°C, plain bearing, no thread guard	100 x 35	41 x 12	40–125
Max loads at temperature (kg)			
	100°C 125	300°C 40	
	250°C 100		



M SERIES FORKS¹

					
High temp	Low temp	High temp	Low temp	High temp	Low temp
MZPHT/ ISO or North American	MZPLT/ ISO or North American	MZFHT/ ISO or North American	MZF/ ISO or North American	MZHHT	MZHLT



* Wheel should be exposed to this temperature for short periods only.

¹ See M, J and O Core fork options for more information.

J SERIES WHEELS



	Diameter x tread (mm)	Hub x bore (mm)	Max load (kg)
 JCI Cast iron, max load at 400°C, plain bearing, no thread guard	100 x 38	45 x 20	230
 JHH Glass reinforced nylon, heavy hub, max load at 210°C, plain bearing, no thread guard	100 x 32	45 x 20	100
Max loads at temperature (kg)			
	150°C 100	210°C 80	
	180°C 90	230°C 60*	

J SERIES FORKS¹



					
High temp	Low temp	High temp	Low temp	High temp	Low temp
JZPHT	JZPLT	JZFHT	JZF	JZHHT	JZHLT

* Wheel should be exposed to this temperature for short periods only.

O SERIES WHEELS

	Diameter x tread (mm)	Hub x bore (mm)	Max load (kg)
 OHH Glass reinforced nylon, heavy hub, max load at 210°C, plain bearing, no thread guard	150 x 40	60 x 20	200
 WCI Cast iron, max load at 400°C, plain bearing, no thread guard	150 x 50	60 x 20	250

O SERIES FORKS¹

			
High temp	Low temp	High temp	Low temp
OZPHT/ ISO or North American	OZPLT/ ISO or North American	HZFHT/ ISO or North American	HZF/ ISO or North American

M SERIES ORDER CODES

Wheel code	Fork code	Castor code
DCI75 High temp Diameter: 75 mm	M75ZPHT	DCI75/MZPHT
	M75ZPNHT	DCI75/MZPNHT
	M75ZFHT	DCI75/MZFHT
	M75ZFNHT	DCI75/MZFNHT
	M75ZHHT	DCI75/MZHHT
MHH100 High temp Diameter: 100 mm	M100ZPHT	MHH100/MZPHT
	M100ZPNHT	MHH100/MZPNHT
	M100ZFHT	MHH100/MZFHT
	M100ZFNHT	MHH100/MZFNHT
	M100ZHHT	MHH100/MZHHT
MHH100 Low temp Diameter: 100 mm	M100ZPLT	MHH100/MZPLT
	M100ZPNLT	MHH100/MZPNLT
	M100ZF	MHH100/MZF
	M100ZFN	MHH100/MZFN
	M100ZHLT	MHH100/MZHLT
MKT100 High temp Diameter: 100 mm	M100ZPHT	MKT100/MZPHT
	M100ZPNHT	MKT100/MZPNHT
	M100ZFHT	MKT100/MZFHT
	M100ZFNHT	MKT100/MZFNHT
	M100ZHHT	MKT100/MZHHT

J SERIES ORDER CODES

Wheel code	Fork code	Castor code
JCI100 High temp Diameter: 100 mm	J100ZPHT	JCI100/JZPHT
	J100ZFHT	JCI100/JZFHT
	J100ZHHT	JCI100/JZHHT
JCI100 Low temp Diameter: 100 mm	J100ZPLT	JCI100/JZPLT
	J100ZF	JCI100/JZF
	J100ZHLT	JCI100/JZHLT
JHH100 High temp Diameter: 100 mm	J100ZPHT	JHH100/JZPHT
	J100ZFHT	JHH100/JZFHT
	J100ZHHT	JHH100/JZHHT
JHH100 Low temp Diameter: 100 mm	J100ZPLT	JHH100/JZPLT
	J100ZF	JHH100/JZF
	J100ZHLT	JHH100/JZHLT

O SERIES ORDER CODES

Wheel code	Fork code	Castor code
OHH150 High temp Diameter: 150 mm	O150ZPHT	OHH150/OZPHT
	O150ZPNHT	OHH150/OZPNHT
	H150ZFHT	OHH150/HZFHT
	H150ZFNHT	OHH150/HZFNHT
OHH150 Low temp Diameter: 150 mm	O150ZPLT	OHH150/OZPLT
	O150ZPNLT	OHH150/OZPNLT
	H150ZF	OHH150/HZF
	H150ZFN	OHH150/HZFN
WCI150 High temp Diameter: 150 mm	O150ZPHT	WCI150/OZPHT
	O150ZPNHT	WCI150/OZPNHT
	H150ZFHT	WCI150/HZFHT
	H150ZFNHT	WCI150/HZFNHT
WCI150 Low temp Diameter: 150 mm	O150ZPLT	WCI150/OZPLT
	O150ZPNLT	WCI150/OZPNLT
	H150ZF	WCI150/HZF
	H150ZFN	WCI150/HZFN

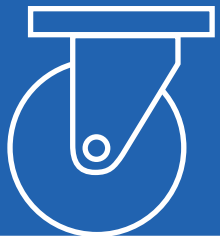

Medical castors



Products imagined by you. Custom made by us.



A leading healthcare equipment company wanted a castor to perfectly match the powder coat colour of their patient lifters and the blue of their company logo. They also required an ultra-low castor for the front of the patient lifter. We matched the colours, and were able to team a wheel with a custom made low-height fork. In addition, we recommended the use of Chicago screw axles (so there are no ankle-biting sharp edges around patients' fragile skin).



A leading design and manufacturing company wanted a castor for a recliner chair that could be activated using purpose-built engagement into a customised pedal (utilising the fixed pedal technology of the Trinity Castor). We added engagement holes into the pedal they designed and moulded in their customised colours, materials and finishes, specified for chemical resistance.



A leading hospital bed manufacturer approached us to develop a castor using their corporate colours with a special pintle to suit their specific dimensions. We adapted our O series castor and developed a special top cap buffer to prevent fluid ingress.



Trinity



Designed for patient transport, Trinity castors are renowned in the healthcare industry for their innovative three-in-one brake function, fixed brake pedal position and high dynamic load rating.

Configuration

Trinity castors are available in three wheel sizes—100, 125 and 150 mm—and four brake configurations:

- Complete brake (CB)—includes all three brake positions
- Total brake (TB)—includes TB and swivel
- Swivel (SW)—free movement castor with no pedal
- Blank castor (BL)—used to achieve bilateral braking. If used at the rear of equipment and combined with CB castors at the front, one activation bar can control all castors to achieve total brake, direction lock or free swivel.

Innovative patented design

Trinity castors and Trinity EBC are designed in Australia and made under the following patents:

- USA patent 8205297 (12/663354)
- European patent 2164715
- Australian patent 2008258348
- International patent pending 20150266342

Three-in-one brake

The advanced braking system provides three brake functions—directional lock (up), free swivel (horizontal) and total brake (down)—controlled by soft touch actuation pedals.

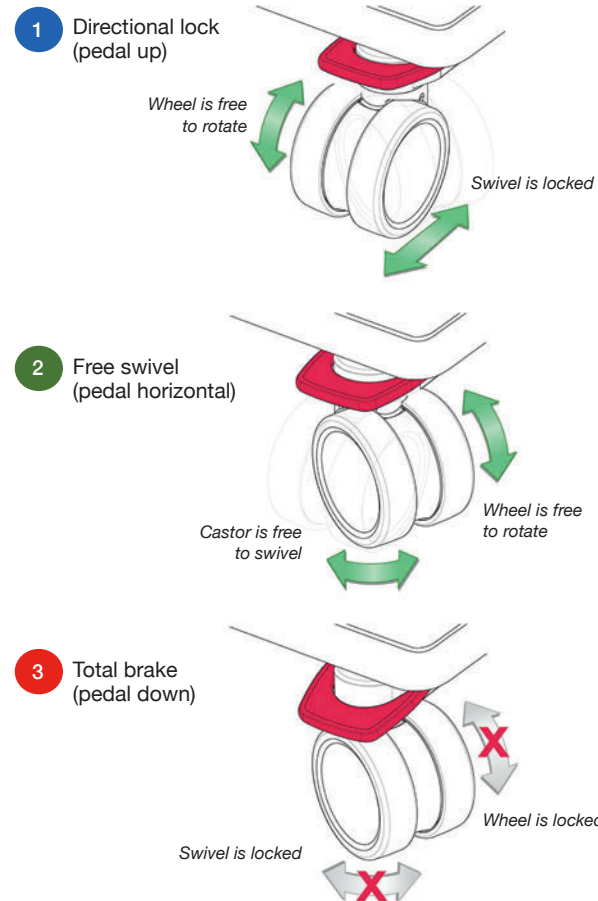

Fixed brake pedal position

A fixed brake pedal means that you can use the castor no matter where it's facing as the pedal will always be accessible. No more fishing under equipment to try to find the pedal.

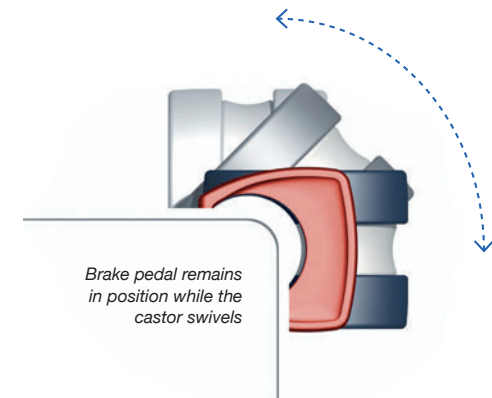

Low mount heights and tight turning radii

	Wheel Diameter	Height* (mm)	Turning radius (mm)
Swivel Swivel only	100	133	85
	125	161	110
	150	185	135
In-line pedal Pedal in-line with directional lock	100	133	85
	125	161	110
	150	185	135
90 degree pedal Pedal at 90 degree angle to directional lock	100	133	85
	125	161	110
	150	185	135

* Mount heights shown are for castors only. Fittings are additional—5 mm for washer, 14 mm for plate.

Trinity Electronic Braking Castors

TRINITYEBC



Built on the innovation of Trinity Castors, Trinity Electronic Braking Castors (EBC) feature automatic brakes, intuitive steering, and the control of brakes and steering from any castor foot pedal, handset or nurse panel.

Never forget the brakes again

In a high pressure environment like a hospital ward, it is very easy to forget to engage the brakes on a hospital bed or on specialised medical equipment. Where medical castors are used for moving patients and specialised equipment frequently, forgetting to apply the brakes presents a higher risk of accidents, especially if the patient tries to alight, or when hospital equipment unexpectedly moves.

Trinity EBC helps prevent these kinds of accidents by automatically applying the brakes when it has been stationary for a programmed time (normally 60 seconds). When you want to unlock the brakes again, the control is always within easy reach—just flick up any of the four castor pedals, or press the button on the handset or nurse control panel.

Steer like you flip your iPhone™

Just like your iPhone™ decides whether to flip its display from portrait to landscape based on your pattern of movement, Trinity EBC analyses how you move the bed or equipment, and intelligently decides when and how to engage or disengage the directional lock. This automates another task you have to remember, enabling you to focus on looking after your patient.

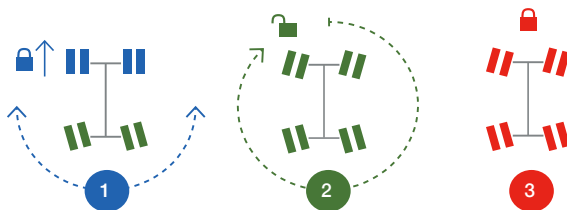

Automatic braking and intuitive steering

- 1 Purposeful movement in either direction engages the directional lock to the forward wheels, allowing the rear wheels to do the steering.
- 2 No movement for one second disengages the directional lock and allows free swivel movement to all four castors.
- 3 No movement for 60 seconds engages total brake on all four castors. This can be disengaged from the handset or by using any of the four pedals.

No power, no problem

In the unlikely event of a power cut, the castors can still be manually steered and locked through the pedals, just like a normal Trinity castor. This allows you to still use the bed normally.

Control System

Trinity EBC is fully customisable. Pair an EBC set with the Fallshaw Control System to get the most out of Trinity EBC, or ask our engineers to help you retrofit EBC to your existing hospital bed system. Ask a Fallshaw representative for more information.

Trinity EBC Set

Trinity EBC can be ordered as a set. An EBC set consists of four castors—one motion sensing and conductive castor, and three standard castors.

FEATURES	100 mm wheel	125 mm wheel	150 mm wheel
Mount height*	133 mm	161 mm	185 mm
Turning radius	85 mm	110 mm	135 mm
Standard fittings	<ul style="list-style-type: none"> • 32 mm pintle or 28 mm ISO pintle • Washer 		
Standard features	<ul style="list-style-type: none"> • IPX5 water resistance rating • Cool grey or eggshell colourway 		
Optional features	<ul style="list-style-type: none"> • Auto brake motion sensor • Intuitive steer motion sensor • Conductive anti-static (resistance < 10⁵ ohms) 		

* Add 5 mm for washer mount.



Trinity EBC can be used on a wide range of medical equipment, including hospital beds, mobile rehab robots and specialised surgical equipment.

Trinity and Trinity EBC fittings and order codes

FITTING OPTIONS

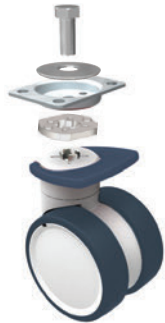
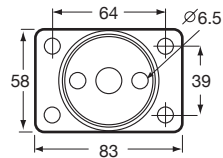

PLATE MOUNT

SPFPLATEKIT

Includes:

- SPM14X40 (bolt)
- SPWSHFZDRILL (fitting washer)
- SPFPLATE (top plate)



Only compatible with 100 mm castors at full load rating.



TUBE MOUNT

Add solid pintle adapter:

- AFR28Z(100) Fits 100 mm castors, 28 mm round stem²
- AFR28Z(125/150) Fits 125 mm & 150 mm castors, 28 mm round stem²
- AFR32Z(100) Fits 100 mm castors, 32 mm round stem³
- AFR32Z(125/150) Fits 125 mm & 150 mm castors, 32 mm round stem³



WASHER MOUNT

Customer supplied M14 bolt and washer to ensure engagement into the castor of 30–38 mm (100) or 40–50 mm (125 and 150).

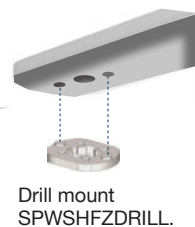
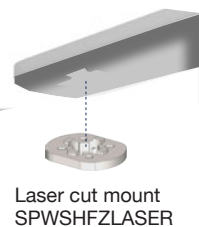

TRINITY ORDER CODES (COMPLETE THE BLANKS)

Castor Series	Tyre material	Bearing	Size (mm)	Fork	Pedal	Colourway	Brake configuration	Fork design				
F	U Polyurethane	Q	100 125 150	F	0 In-line 9 90°	C Cool grey E Eggshell	CB Complete brake TB Total brake SW Swivel BL Blank	S Standard A Anti-static				
F	—	Q	—	F	—	—	—	—				

TRINITY EBC SINGLE REPLACEMENT ORDER CODES (COMPLETE THE BLANKS)

Castor Series	Tyre material*	Bearing	Size (mm)	Fork	Pedal	Colourway	Brake configuration	Fork design*	Steering type ¹	Cable compatibility	Motion-sensing ¹	Water resistance
F	U Polyurethane A Anti-static	Q	100 125 150	P	0 In-line 9 90°	C Cool grey E Eggshell	CB Complete brake TB Total brake BL Blank	S Standard A Anti-static	I Intuitive U User specified	L Linak D Dewert T TiMotion	M Yes N No	5 IPX5 6 IPX6
F	—	Q	—	P	—	—	—	—	—	—	—	—









* Tyre material and fork design—polyurethane tyre (U) can only be matched with standard fork (S). Anti-static tyre (A) can only be matched with anti-static fork.

¹ Steering type and motion sensing—intuitive steering (I) can only be matched with motion sensing (M: Yes).

² Cross drill hole: distance from end—19 mm, diameter—8 mm.

³ Cross drill hole: distance from end—7 mm, diameter—6 mm.

TRINITY EBC CONTROL SYSTEM OPTIONS

	EBCCONTROLU (User-specified) EBCCONTROLI (Intuitive)
EBC Controller	
	EBCCABLESET1.5 (Set of four 1.5 m cables)
Extension cable set	
	EBCCABLEY
Y cable	
	EBCBATTERY1
Battery	
	EBCPOWERAU (Australasian) EBCPOWEREU (European) EBCPOWERUK (UK) EBCPOWERUS (US)
Power supply	
	EBCHANDSETU1 (User-specified, 1 button) EBCHANDSETU5 (User-specified, 5 button) EBCHANDSETI1 (Intuitive, 1 button) EBCHANDSETI6 (Intuitive, 6 button)
Handset	
	EBCPANELI1 (Intuitive, 1 button)
Nurse Panel	
	EBCINTERFACE (If using existing control panel)
Interface Box	

TRINITY EBC SET ORDER CODES (COMPLETE THE BLANKS)

Castor Series	Size	Pedal configuration	Colourway	Brake configuration	Steering type	Cable compatibility	Water resistance
EBCSET	100 100 mm	0 <i>In-line</i>	C <i>Cool grey</i>	CB <i>Complete brake</i>	I <i>Intuitive</i>	L <i>Linak</i>	5 <i>IPX5</i>
	125 125 mm						
	150 150 mm						
EBCSET	—	—	—	—	—	—	—

EBC Sets include one anti-static, motion-sensing castor and three standard castors.



Trinity EBC Colour coded feature identification

- Blue—Intuitive steering
- Black—Motion sensing
- White—IPX6 water resistance
- Yellow—Conductive (anti-static)



Central locking castor options for hospital beds

We have two options for central locking castors for hospital beds—the traditional mechanical system, and the innovative Trinity Electronic Braking Castors.

Traditional mechanical system

Castors are operated via a foot pedal, which one (typically) moves DOWN for total brake, HORIZONTAL for swivel, and UP for directional lock (steer). The foot pedal is connected via transmission levers and a hexagonal rod running through the bed undercarriage, which, in turn rotates cams inside the castors to control the brake state in all four castors centrally. Steering needs to be factory fitted to either steer from the head end or the foot end of the bed.

See page 41.

Trinity EBC system

Trinity EBC can be controlled with the push of a button via the handset, or by activating any of the four castors (which will then control their companion castors). Steering can flip from the head end of the bed to the foot end automatically.

The EBC technology connects all four castors with electronic cables instead of a hexagonal rod and transmission levers. This provides great flexibility in bed design, where the undercarriage no longer needs to provide for the rigid hexagonal bars, and the cables can bend to any shape. Additionally, Trinity EBC can be retro-fitted to existing hospital beds.

See page 37.



Traditional mechanical system

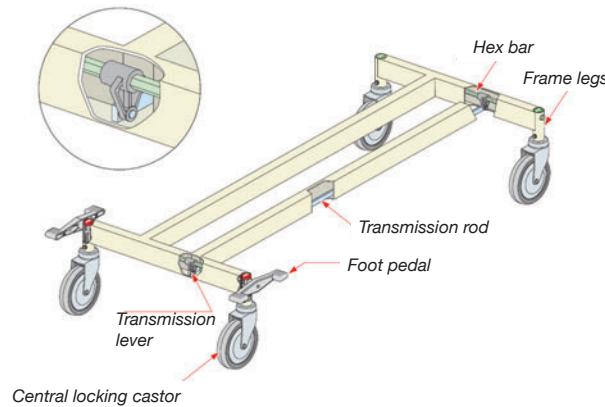

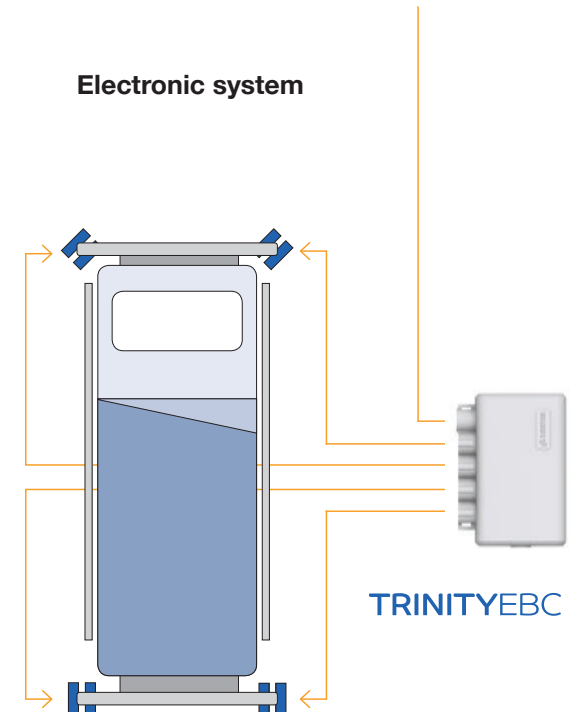

OR

Electronic system



Traditional central locking castors

WHEELS

	Diameter x tread (mm)	Max load (kg)
 CUQ (Twin wheel) Polyurethane, precision bearing, thread guard	150 x 32	100
 MJQ TPE, precision bearing, thread guard	100 x 32 125 x 32	100 100
 QTQ Grey energy absorbent elastomer, round profile, precision bearing, thread guard	150 x 32	100



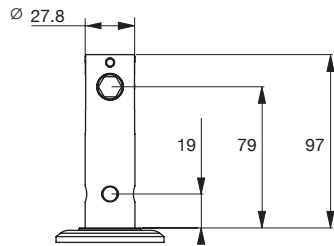

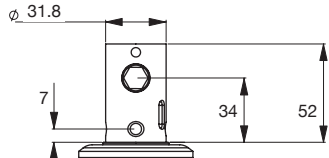

Long pintle
(order code includes 'L')



Short pintle
(order code includes 'S' and is made to order)



FORKS

	Wheel Diameter	Height (mm)	Turning radius (mm)
 CNL/CZL Long pintle with swivel	100	139	91
	125	165	103
	150	190	113
 CNLTB/CZLTB Long pintle with total brake	100	139	91
	125	165	103
	150	190	113
 CNLDL/CZLDL Long pintle with direction lock	100	139	91
	125	165	103
	150	190	113
 CNS/CZS Short pintle with swivel	100	139	91
	125	165	103
	150	190	113
 CNSTB/CZSTB Short pintle with total brake	100	139	91
	125	165	103
	150	190	113
 CNSDL/CZSDL Short pintle with direction lock	100	139	91
	125	165	103
	150	190	113

ORDER CODES

Wheel code	Fork code	Castor code
CUQ150GT	C150NL	CUQ150GT/CNL
Diameter: 150 mm	C150NLTB	CUQ150GT/CNLTB
	C150NLDL	CUQ150GT/CNLDL
	C150NS	CUQ150GT/CNS
	C150NSTB	CUQ150GT/CNSTB
	C150NSDL	CUQ150GT/CNSDL
MJQ100G	C100ZL	MJQ100G/CZL
Diameter: 100 mm	C100ZLTB	MJQ100G/CZLTB
	C100ZLDL	MJQ100G/CZLDL
	C100ZS	MJQ100G/CZS
	C100ZSTB	MJQ100G/CZSTB

ORDER CODES

Wheel code	Fork code	Castor code
MJQ125G Diameter: 125 mm	C100ZSDL	MJQ100G/CZSDL
	C125ZL	MJQ125G/CZL
	C125ZLTB	MJQ125G/CZLTB
	C125ZLDL	MJQ125G/CZLDL
	C125ZS	MJQ125G/CZS
	C125ZSTB	MJQ125G/CZSTB
QTQ150G Diameter: 150 mm	C125ZSDL	MJQ125G/CZSDL
	C150ZL	QTQ150G/CZL
	C150ZLTB	QTQ150G/CZLTB
	C150ZLDL	QTQ150G/CZLDL
	C150ZS	QTQ150G/CZS
	C150ZSTB	QTQ150G/CZSTB
	C150ZSDL	QTQ150G/CZSDL
Sets—2 x Total Brake, 2 x Direction Lock, 2 x Transmission Levers		
CUQ150GT	Long pintle	CUQ150GTCLLSET
	Short pintle	CUQ150GTCLSSET
MJQ100G	Long pintle	MJQ100GCLLSET
	Short pintle	MJQ100GCLSSET
MJQ125G	Long pintle	MJQ125GCLLSET
	Short pintle	MJQ125GCLSSET
QTQ150G	Long pintle	QTQ150GCLLSET
	Short pintle	QTQ150GCLSSET

FITTING OPTIONS



SPMCLNS28SPLIT
Square adaptor to suit 28mm ID tube



SPPEDCL(L)—Left hand side control pedal
SPPEDCL(R)—Right hand side control pedal



SPMCLTL—lever for long ISO pintle
SPMCSTL—lever to suit the short pintle

Wheelchair castors



Wheel	Diameter x tread (mm)	Hub width (mm)	Weight (kg)	Max load (kg)	Fork	Height (mm)	Turning radius (mm)
CFQ	175 x 45	50 x 8	1.07	45	CPH	225	130
Foamed urethane, precision bearing, no thread guard	200 x 45	50 x 8	1.27	45	Bolt hole swivel	237	144

ORDER CODES

Wheel code	Fork code	Castor code
CFQ175 —Diameter: 175 mm	C175PH	CFQ175/CPH
CFQ200 —Diameter: 200 mm	C200PH	CFQ200/CPH

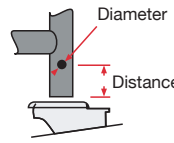

SOLID PINTLE MOUNT

Stem OD	Tube size (OD x Wall)	Cross drill hole (distance from end x diameter)	Order code
19 mm round	22 x 1.2 mm		-AR19Z
22 mm round	25 x 1.6 mm		-AR22Z
-AR19 with adapter 22 mm square	25 x 1.6 mm SQ		-AS22Z
28 mm round	32 x 1.6 mm		-AR28Z

Conductive (anti-static) wheels

Designed for use in Electrostatic Discharge (ESD) environments as part of an effective ESD Control Program, our anti-static non-marking wheels can be assembled into our M series castors.

Anti-static wheels have conductivity of $<10^6$, exceeding the requirement of ANSI/ESD S20.20-1999 for Mobile Equipment in Protected Areas, which specify 10^9 as the maximum level of resistance.

Installation of ESD wheels

ESD wheels must be properly installed to ensure a conductive path from the trolley leg, through the stem, and the castor and the axle and the bearing, and through the centre and tyre. Solid metal pintles will provide such a conductive path. If plastic expanding stems are selected, they will need to be installed with a copper wire attached to the stem and wrapped between the adaptor and tube inner to ensure a conductive path.

WHEELS

	Diameter x tread (mm)	Hub x bore (mm)	Max load (kg)
 MAQ*	75 x 32	40 x 8	85
TPE, precision bearing, thread guard	100 x 32	40 x 8	85
	125 x 32	40 x 8	85

* See page 12 for M Series fork options. Also available with stainless steel bearing—MAC—for M Powder coat (page 27) and M Stainless Steel (page 28) castors.



Decorative castors



Arc range

The Arc range of castors are designed with crisp, clean finishes ideally suited to modern, contemporary furniture.

Arc Castors are based on our K Series and M Series ranges, but with decorative finishes, power coated in Anodic natural matt, with grey pedals and seals, and Chicago screw axles. Wheels come in four colourways—graphite, silver, white and clear, all with pearlescent pigment in the thread guards for that sophisticated high lustre look.

The 75 mm and 100 mm sizes are stocked and available for next-day delivery as shown. The K Series version can also be made to order in 65 mm and 100 mm sizes, while the M Series version can be made to order in 75 mm and 125 mm sizes, subject to a minimum order quantity of 200 pieces.



COLOURWAY

To order a colourway, add the colourway code to the end of castor code prior to ordering (e.g. KJQ75G/KPPGH).

Colourway

K Series

M Series

GH
Graphite



SL
Silver



WT
White





GY
Clear grey







Clear grey colourway is only compatible with KVP wheel.

K SERIES WHEELS

	Diameter x tread (mm)	Hub x bore (mm)	Max load (kg)
 KJQ TPE, precision bearing, thread guard	75 x 23	30 x 8	50
 KVP Transparent grey PVC, plain bearing, no thread guard	75 x 23	30 x 8	45

K SERIES FORKS

	Wheel Diameter	Height (mm)	Turning radius (mm)
 KPP Plate with swivel	75	104	69
 KPPTB Plate with swivel and total brake	75	104	89
 KPH Bolt hole swivel	75	104	69
 KPHTB Bolt hole swivel and total brake	75	104	89





K SERIES ORDER CODES

Wheel code	Fork code	Castor code	Colourway
KJQ75G Diameter: 75 mm	K75PP	KJQ75G/KPP	+ ____
	K75PPTB	KJQ75G/KPPTB	+ ____
	K75PH	KJQ75G/KPH	+ ____
	K75PHTB	KJQ75G/KPHTB	+ ____
KVP75 Diameter: 75 mm	K75PP	KVP75/KPP	+ GY
	K75PPTB	KVP75/KPPTB	+ GY
	K75PH	KVP75/KPH	+ GY
	K75PHTB	KVP75/KPHTB	+ GY

M SERIES WHEEL

	Diameter x tread (mm)	Hub x bore (mm)	Max load (kg)
 MJQ TPE, precision ball bearing, thread guard	100 x 32	40 x 8	85

M SERIES FORKS

	Wheel Diameter	Height (mm)	Turning radius (mm)
 MPP Plate with swivel	100	135	91
 MPPTB Plate with swivel and total brake	100	135	128
 MPH Bolt hole swivel	100	135	91
 MPHTB Bolt hole swivel and total brake	100	135	128

M SERIES ORDER CODES

Wheel code	Fork code	Castor code	Colourway
MJQ100G Diameter: 100 mm	M100PP	MJQ100G/MPP	+ ____
	M100PPTB	MJQ100G/MPPTB	+ ____
	M100PH	MJQ100G/MPH	+ ____
	M100PHTB	MJQ100G/MPHTB	+ ____



Zen range



The Zen range of castors are designed with earthy, warm tones to complement timber furniture.

Zen castors are based on our K Series and M Series castors, decoratively finished in a 'storm front' powder coat—a warm, dark grey with a tiny hint of olive, complemented with charcoal pedals and seals, and Chicago screw axles. The wheels come with thread guards in a titanium coloured pearlescent pigment, for that high lustre sophistication.

The 75 mm and 100 mm sizes are stocked and available for next-day delivery as shown. The K Series version can also be made to order in 65 mm & 100 mm sizes, while the M Series version can be made to order in 75 mm and 125 mm sizes, subject to a minimum order quantity of 200 pieces.

COLOURWAY

Colourway

K Series





M Series



K SERIES WHEEL

	Diameter x tread (mm)	Hub x bore (mm)	Max load (kg)
 KJQ TPE, precision bearing, thread guard	75 x 23	30 x 8	50

K SERIES FORKS

	Wheel Diameter	Height (mm)	Turning radius (mm)
 KPP Plate with swivel	75	104	69
 KPPTB Plate with swivel and total brake	75	104	89
 KPH Bolt hole swivel	75	104	69
 KPHTB Bolt hole swivel and total brake	75	104	89





K SERIES ORDER CODES

Wheel code	Fork code	Castor code
KJQ75G Diameter: 75 mm	K75PP	KJQ75G/KPPTM
	K75PPTB	KJQ75G/KPPTBTM
	K75PH	KJQ75G/KPHTM
	K75PHTB	KJQ75G/KPHTBTM

M SERIES WHEEL

	Diameter x tread (mm)	Hub x bore (mm)	Max load (kg)
 MJQ TPE, precision ball bearing, thread guard	100 x 32	40 x 8	85

M SERIES FORKS

	Wheel Diameter	Height (mm)	Turning radius (mm)
 MPP Plate with swivel	100	135	91
 MPPTB Plate with swivel and total brake	100	135	128
 MPH Bolt hole swivel	100	135	91
 MPHTB Bolt hole swivel and total brake	100	135	128

M SERIES ORDER CODES

Wheel code	Fork code	Castor code
MJQ100G Diameter: 100 mm	M100PP	MJQ100G/MPPTM
	M100PPTB	MJQ100G/MPPTBTM
	M100PH	MJQ100G/MPHTM
	M100PHTB	MJQ100G/MPHTBTM

M Deluxe range



Boasting elegant sophistication, the M Deluxe castor will complement your high end furniture, display, or equipment. Based on the M Series castors, the M Deluxe is fitted with a 100 mm or 125 mm TPE wheel, precision bearings and thread guard. The chrome-plated forks are fitted with Chicago screw axles.

COLOURWAY

Colourway

M Series





BN
Bluestone



WHEEL

	Diameter x tread (mm)	Hub x bore (mm)	Max load (kg)
 MJQ	100 x 32	40 x 8	85
TPE, precision ball bearing, thread guard	125 x 32	40 x 8	85

FORKS

	Wheel Diameter	Height (mm)	Turning radius (mm)
 MCP Plate with swivel	100 125	135 161	91 103
 MCPTB Plate with swivel and total brake	100 125	135 161	128 128
 MCF Fixed plate, no swivel	100 125	135 161	- -
 MCH Bolt hole swivel	100 125	135 161	91 103
 MCHTB Bolt hole swivel and total brake	100 125	135 161	128 128

ORDER CODES

Wheel code	Fork code	Castor code
MJQ100G Diameter: 100 mm	M100CP	MJQ100G/MCPBN
	M100CPTB	MJQ100G/MCPTBBN
	M100CF	MJQ100G/MCFBN
	M100CH	MJQ100G/MCHBN
	M100CHTB	MJQ100G/MCHTBBN
MJQ125G Diameter: 125 mm	M125CP	MJQ125G/MCPBN
	M125CPTB	MJQ125G/MCPTBBN
	M125CF	MJQ125G/MCFBN
	M125CH	MJQ125G/MCHBN
	M125CHTB	MJQ125G/MCHTBBN



Build your own castor

Your castor, your way.

Sometimes you just need castors that look different. Whether it's to match a piece of furniture you've designed, to complement your flooring, or just to give your proudly created masterpiece that upmarket touch, we can help you design and build the perfect castor for you.

Because we make our own castors, we can help product designers and manufacturers create their perfect castor with customised colours, wheel materials, fork finish.

We recently helped a leading furniture manufacturer with a total brake castor for their exclusive new lounge collection. With our team's help, we supplied the perfect castor, with colours and elements combined from the Arc, Zen and M Deluxe ranges.

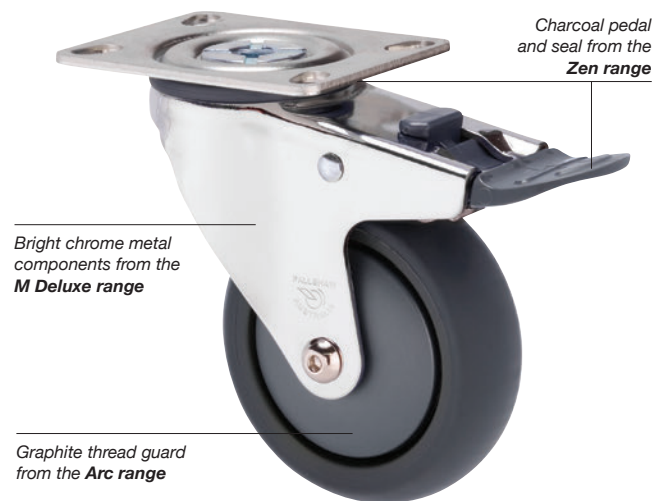



Castors that look the part

A leading manufacturer of high-end wooden furniture needed castors to complement their exclusive range. We supplied a castor that mixed and matched the bright chrome components from the M Deluxe range, the charcoal wheel from the Zen range, and colour-matched a custom colour for the thread guard and pedal.

If you are looking for a particular colourway to match your equipment or furniture, where volume permits, we have a large library of masterbatch colours to choose from. Alternatively we can match any colour from a swatch or a Pantone reference number, ensuring that you'll get the look you want.





Wheels



Hard wheels



NYLON

	Diameter x tread (mm)
 DNQ Hard nylon, precision bearing, no thread guard	125 x 32
 DNQ...W Hard nylon, precision bearing, no thread guard	125 x 32
 LNN Hard nylon, plain bearing, no thread guard	50 x 20
 KNN Hard nylon, plain bearing, no thread guard	65 x 23 75 x 23 100 x 23
 MNN Hard nylon, plain bearing, no thread guard	75 x 32 100 x 32 125 x 32
 MNN...W White hard nylon, plain bearing, no thread guard	75 x 32 100 x 32 125 x 32
 JNN Hard nylon, plain bearing, no thread guard	100 x 35 125 x 35
 JNR Hard nylon, roller bearing, optional thread guard	100 x 35 125 x 35
 ONA Hard nylon, plain bearing, no thread guard	100 x 40 125 x 40 150 x 40 200 x 40
 ONR Hard nylon, roller bearing, no thread guard	100 x 40 125 x 40 150 x 40 200 x 40

NYLON

	Diameter x tread (mm)
 WNQ Hard nylon, precision bearing, no thread guard	150 x 40 200 x 40

PALLET TRUCK WHEELS

	Diameter x tread (mm)
 PLN Nylon, available in, 20 mm (Q20), 25 mm (Q25) and 3/4" (Q34) precision bearings, or no bearing (QNB)	82 x 100 200 x 48
 PLU Polyurethane, available in, 20 mm (Q20), 25 mm (Q25) and 3/4" (Q34) precision bearings, or no bearing (QNB)	200 x 48

ORDER CODES

	Max load (kg)	Hub x bore (mm)
Nylon		
DNQ125	200	40 x 8
DNQ125W	200	40 x 8
LNN50	30	25 x 6
KNN65	50	30 x 8
KNN75	65	30 x 8
KNN100	70	30 x 8
MNN75	150	40 x 8
MNN100	150	40 x 8
MNN125	150	40 x 8
MNN75W	150	40 x 8
MNN100W	150	40 x 8
MNN125W	150	40 x 8
JNN100	300	45 x 10

ORDER CODES









	Max load (kg)	Hub x bore (mm)
JNN125	300	45 x 10
JNR100	300	45 x 10
JNR125	300	45 x 10
ONA100	350	60 x 12.7
ONA125	400	60 x 12.7
ONA150	450	60 x 12.7
ONA200	500	60 x 12.7
ONR100	350	60 x 12.7
ONR125	400	60 x 12.7
ONR150	450	60 x 12.7
ONR200	500	60 x 12.7
WNQ150	600	60 x 12.7
WNQ200	600	60 x 12.7

Pallet Truck Wheels

PLN82X100Q20	800	100 x 20
PLN82X100Q25	800	100 x 25
PLN82X100Q34	800	100 x 19
PLN82X100QNB	800	100 x n/a
PLN200X48Q20	700	48 x 20
PLN200X48Q25	700	48 x 25
PLN200X48Q34	700	48 x 19
PLN200X48QNB	700	48 x n/a
PLU200X48Q20	700	48 x 20
PLU200X48Q25	700	48 x 25
PLU200X48Q34	700	48 x 19
PLU200X48QNB	700	48 x n/a



















Polyurethane wheels

	Diameter x tread (mm)
 AUQ Polyurethane on cast iron, precision bearing, no thread guard	200 x 102 250 x 102
 HUR Polyurethane on nylon, roller bearing, optional thread guard (150 mm wheel only)	100 x 40 125 x 40 150 x 40 200 x 48
 HUS* Polyurethane on nylon, stainless steel roller bearing, no thread guard	100 x 32 125 x 40 150 x 40 200 x 48
 JUR* Polyurethane, roller bearing, optional thread guard	100 x 32 125 x 38
 KUQ* Polyurethane, precision bearing, optional thread guard	75 x 23 100 x 23
 QUQ¹ Polyurethane tyre on nylon, precision bearing, thread guard	75 x 32 100 x 32 125 x 32
 VUQ Polyurethane on cast iron, precision bearing, no thread guard	203 x 75 254 x 75
 WUQ Polyurethane, precision bearing, no thread guard	150 x 40 200 x 40
 XUQ Polyurethane on cast iron, precision bearing, no thread guard	102 x 50 127 x 50 152 x 50 203 x 50





* Also available with plain bearing—HUA, JUA, KUA.

¹ Also available with plain bearing (QUA) and stainless steel bearing (QUC).

Soft wheels

GREY RUBBER		Diameter x tread (mm)
 HSR Grey rubber, energy absorbent, roller bearing, thread guard available (add G to the end of code)		200 x 50
 KSA Grey rubber, flat profile, plain bearing		65 x 23 75 x 23 100 x 23
 PSA Grey rubber, non-marking, white polypropylene offset wheel, plain bearing. Developed for floor polishers and scrubbers. Also available to suit 5/8" bore (58)		200 x 32
 PSB Grey rubber, non-marking, white polypropylene offset wheel, deep groove ball bearing. Developed for floor polishers and scrubbers		200 x 32
 STQ Grey energy absorbent elastomer, round profile, precision bearing, thread guard		75 x 32 100 x 32 125 x 32
BLUE RUBBER		Diameter x tread (mm)
 CBQ Blue high resilience elastomer, precision bearing, thread guard		75 x 33 100 x 33 125 x 33
 HBR Blue high-resilient rubber, non-marking, long life, roller bearing		150 x 40 200 x 50
 JBR Blue high-resilient rubber, non-marking, long life, roller bearing		100 x 32 125 x 32
 MBQ Blue high-resilient rubber, non-marking, long life, precision ball bearing, thread guard		100 x 32 125 x 32
BLUE RUBBER		Diameter x tread (mm)
 OBQ Blue high-resilient rubber, non-marking, long life, precision ball bearing		100 x 50 125 x 50 150 x 50 200 x 50
BLACK RUBBER—SMALL		Diameter x tread (mm)
 PRB* General purpose rubber utility wheel for lawn equipment and carts, deep groove ball bearing and offset centre		125 x 36 150 x 36 200 x 36
 RB200L Solid black rubber wheel, with roller bearing, for wheelbarrows, utility equipment and waste bins		200 x 45
 U200/60C Medium duty hand truck wheels, deep groove ball bearing, high-impact polypropylene centre, 20 mm bore (-POYB20) or 3/4" bore (-POYB34)		200 x 60
BLACK RUBBER—LARGE		Diameter x tread (mm)
 PRP250 General purpose rubber utility wheel, used on light lawn equipment and carts, plain bearing. Optional hubcap available (GHUBCAP)		250 x 45
 R250/50C¹ Puncture proof for wheelbarrows and utility equipment, precision ball bearing. Available in 20 mm bore (-PRYQ20) or 3/4" bore (-PRYQ34)		250 x 50
 R300/50C¹ Puncture proof for wheelbarrows and utility equipment, precision ball bearing. Available in 20 mm bore (-PRYQ20) or 3/4" bore (-PRYQ34)		300 x 50

BLACK RUBBER – LARGE

	Diameter x tread (mm)
 R400/70C¹ Puncture proof for wheelbarrows and utility equipment, precision ball bearing. Available in 20 mm bore (-PRYQ20), 3/4" bore (-PRYQ34), or 1" bore (PRYQ25)	400 x 70
 R250/75C² Puncture proof for wheelbarrows and utility equipment, precision ball bearing. Available in 20 mm bore (-PRWQ20), 25 mm bore (-PRWQ25), 3/4" bore (-PRWQ34), or 5/8" bore (-PRWQ58)	250 x 75
 R280/70R Puncture proof solid cushioned wheel, with deep groove ball bearings in sizes 1" (-SRBB10), 20 mm (-SRBB20), 3/4" (-SRBB34), or 5/8" (-SRBB58)	280 x 70
 R400X8-SQ10 Heavy duty wheel, designed for towing, precision ball bearing. Max tow speed—15 km/h	400 x 95

ORDER CODES

	Max load (kg)	Hub x bore (mm)
Polyurethane		
AUQ200	3000	109 x 30
AUQ250	3500	109 x 30
HUR100	300	60 x 12.7
HUR125	350	60 x 12.7
HUR150	450	60 x 12.7
HUR200	500	60 x 12.7
HUS100	300	60 x 12.7
HUS125	350	60 x 12.7
HUS150	450	60 x 12.7
HUS200	500	60 x 12.7
JUR100	300	45 x 10
JUR125	300	45 x 10

ORDER CODES

	Max load (kg)	Hub x bore (mm)
KUQ75	100	30 x 8
KUQ100	100	30 x 8
QUQ75	200	40 x 8
QUQ100	200	40 x 8
QUQ125	200	40 x 8
VUQ200	2000	89 x 20
VUQ250	2000	89 x 20
WUQ150	600	60 x 12.7
WUQ200	600	60 x 12.7
XUQ100	600	62 x 12.7
XUQ125	800	62 x 12.7
XUQ150	1000	62 x 12.7
XUQ200	1000	62 x 12.7
Grey Rubber		
HSR200	250	60 x 12.7
KSA65	50	30 x 12
KSA75	50	30 x 12
KSA100	50	30 x 12
PSA200	80	38 x 12.7
PSA200(58)	80	38 x 16
PSB200	80	38 x 12.7
STQ75	100	40 x 8
STQ100	100	40 x 8
STQ125	100	40 x 8
200X50RIB-PR20	75	60 x 20
200X50RIB-PQ12	75	60 x 12
P200X50RIB-SQ05	50	60 x 12.7
Blue Rubber		
CBQ75	85	40 x 8
CBQ100	100	40 x 8
CBQ125	100	40 x 8

ORDER CODES

	Max load (kg)	Hub x bore (mm)
HBR150	230	60 x 12.7
HBR200	250	60 x 12.7
JBR100	150	45 x 10
JBR125	180	45 x 10
MBQ100G	140	40 x 8
MBQ125G	150	40 x 8
OBQ100	300	60 x 12.7
OBQ125	350	60 x 12.7
OBQ150	400	60 x 12.7
OBQ200	400	60 x 12.7
Black Rubber—Small		
PRB125	50	38 x 13
PRB150	75	38 x 13
PRB200	100	38 x 13
RB200L	200	53 x 25.4
U200/60C-POYB20	135	60 x 20
U200/60C-POYB34	135	60 x 19
Black Rubber—Large		
PRP250	100	48 x 16
R250/50C-PRYQ20	150	60 x 20
R300/50C-PRYQ20	150	60 x 20
R400/70C-PRYQ20	150	80 x 20
R250/75C-PRWQ20	180	75 x 20
R280/70R-SRBB10	200	60 x 25
R400X8-SQ10	600	80 x 25

* Also available with plain bearing—PRA.

¹ 5/8" and 3/4" precision ball bearing or plain bush available.

² 20 mm, 5.8", 3/4" deep groove ball bearing, or 5/8", 3/4" plain bush available.

Pneumatic wheels

Semi-pneumatic puncture-proof wheels

Polyurethane foam-filled tyres are the premium 'pneumatic' (or semi-pneumatic) wheel option. The wheels are puncture proof and provide the greatest performance and reliability. Semi-pneumatics are fitted to two piece wobble-free centres, manufactured from 1.8 mm steel.



Steel 'split rim' tube type wheels

Supplied with tubes for high performance and improved weight carrying capacity. These wheels can be retrofitted with tubes if original tyres are punctured*. Steel centred wheels provide higher load capacity and reliable long life performance. Sizes up to and including the 500x6 are manufactured from 1.8 mm steel, and the 650x8 is of 2 mm thick steel.











Plastic centred tube type wheels

Plastic centred pneumatics are supplied with butyl rubber seamless (butt-joined) tubes as standard. These premium tubes provide greater reliability and longer life than cheaper alternatives. Tubes can be replaced if originals are punctured*. Plastic centred wheels are the low cost alternative, with excellent performance in wet and corrosive environments.

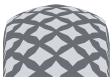

TREAD OPTIONS

	RIB	Straight lines, grey non-marking rubber. Common for wheelchairs and light duty trolleys that need a softer ride.
	LUG	General purpose, outside use. Strongly marked cross lines on a fairly flat tread surface. Good for running in a straight line.
	LGG	Use LGG code for grey non-marking rubber.
	IND	The normal industrial type tread, a round profile with an even pattern.
	DMD	Chunky Diamond or Star shaped pads on a flatter surface. Often used in rougher construction sites. Good for softer grass surfaces but may become clogged with mud.
	STR	
	KNO	This knobby pattern is often preferred for outdoor use, good for gravel or uneven terrain.
	HWY	Jagged lines on a thick, 6 ply tyre designed to have a higher load rating for industrial work sites.

* See page 61 for spare parts.



Pneumatic puncture proof wheels

Puncture proof

Polyurethane foam-filled tyres are premium pneumatic (or semi-pneumatic) puncture proof wheels that provide the greatest performance and reliability. The foam filling provides a light-weight bouncy performance, similar to air-filling, but without the risk of flat tyres. Semi-pneumatics are fitted to two piece wobble-free steel centres. Manufactured from 1.8 mm steel. Some of the cheaper centres on the market are manufactured from steel as thin as 0.6 mm.

Bearings

'Deep Groove' shielded bearings (indicated in order codes with a **B**) fitted to a toughened heavy duty housing enables true running and extra strength. Deep groove bearings can last up to 3 times longer than normal pressed bearings. Precision bearings (indicated in order codes with a **Q**) provide ultra-tight tolerances.

Tyres





4 ply for longer, rougher life (many imports use 2 ply).

For wheels pulled or pushed at low speeds (not driven) the tread pattern is not critical. The following are standard. Other patterns can be offered by negotiation.

Maximum load capacity

Each wheel can carry the recommended load capacity at walking pace—8 km/h. If you are intending to tow your load, it is recommended that you do not exceed 15 km/h, while carrying half the recommended load capacity.

ORDER CODES

Tread	Type	Diameter x tread (mm)	Hub x bore (mm)	Max load (kg) at 8 km/h	Max load (kg) at 15 km/h	Order code	Rim and bearing code
 Non-marking	200 x 50	200 x 50	60 x 12.7	50	Not suitable	P200X50RIB	-SQ05 1/2"
	250 x 4	220 x 54	60 x 20 60 x 19 60 x 16	75	40	P250X4LUG	-SB20 20 mm -SB34 3/4" -SB58 5/8" -SQ15 15 mm
	250 x 6	275 x 65	60 x 20 60 x 19 60 x 16	90	50	P250X6IND	-SB10 1" -SB20 20 mm -SB34 3/4" -SB58 5/8" -SQ15 15 mm
	350 x 4	265 x 70	60 x 20 60 x 19 60 x 16	100	70	P350X4STR	-SB20 20 mm -SB34 3/4" -SB58 5/8" -SQ15 15 mm
	400 x 8	400 x 100	80 x 25.4 84 x 20 84 x 19 84 x 16	120	90	P400X8KNO	-SB10 1" -SB20 20 mm -SB34 3/4" -SB58 5/8" -SQ15 15 mm



Pneumatic steel centred wheels

ORDER CODES

Traditional 'split-rim' steel centred pneumatics (with inner tubes)

- Split rim strong wobble-free wheels. Centres up to and including the 500 x 6 are manufactured from 1.8 mm steel, and the 650 x 8 is of 2 mm thick steel. Some of the cheaper centres on the market are manufactured from steel as thin as 0.6 mm.
- High engineering standards for wobble-free wheels.
- High quality butyl rubber seamless (butt-joined) tubes.

Bearings

'Deep Groove' shielded bearings (indicated in order codes with a **B**) fitted to a toughened heavy duty housing enables true running and extra strength. Deep groove bearings can last up to 3 times longer than normal pressed bearings. Precision bearings (indicated in order codes with a **Q**) provide ultra-tight tolerances.

Tyres

4 ply (6 ply on HWY tread) for longer, rougher life. Many imports use as little as 2 ply thickness.

For wheels pulled or pushed at low speeds (not driven) the tread pattern is not critical. The following are standard. Other patterns can be offered by negotiation.

It is normal for air filled wheels to lose tyre pressure over time even if they are not being used and it's important for your safety that you ensure that the wheels are pumped up to their recommended PSI before use—alternatively you can use our semi-pneumatic puncture proof wheels in applications that require wheels to never go flat.

For non-marking tyres, see our puncture proof wheels (previous page) or plastic centred wheels (next page).

Warning

Do NOT inflate over recommended tyre inflation pressure (30 psi).

Do NOT allow tyre pressure to drop below 20 psi or wheel may deflate and become very difficult to re-inflate. If you allow the tyre to go flat and you are unable to re-inflate it then you may need to buy an inner tube to be retro fitted to the wheel (see page 61 for spare parts). USE OF PNEUMATIC WHEELS OTHER THAN AS RECOMMENDED CAN BE DANGEROUS.

Tread	Type	Diameter x tread (mm)	Hub x bore (mm)	Max load (kg) at 8 km/h	Max load (kg) at 15 km/h	Order code	Rim and bearing code	
	250 x 4	220 x 54	60 x 20	120	100	250X4LUG*	-SB20	20 mm
			60 x 19				-SB34	3/4"
			60 x 16				-SB58	5/8"
	300 x 4	250 x 70	60 x 20	140	110	300X4DMD*	-SB20	20 mm
			60 x 19				-SB34	3/4"
			60 x 16				-SB58	5/8"
	350 x 4	265 x 70	60 x 20	180	160	350X4STR*	-SB20	20 mm
			60 x 19				-SB34	3/4"
			60 x 16				-SB58	5/8"
	250 x 6	275 x 65	60 x 25.4	140	110	250X6IND ¹	-SB10	1"
			60 x 20				-SB20	20 mm
			60 x 19				-SB34	3/4"
	350 x 6	320 x 80	60 x 16	200	180	350X6KNO ¹	-SB58	5/8"
			60 x 25.4				-SB10	1"
			60 x 20				-SB20	20 mm
	400 x 8	400 x 100	60 x 19	360	340	400X8HWY ¹	-SB34	3/4"
			60 x 16				-SB58	5/8"
			70 x 25.4				-SB10	1"
	400 x 8	400 x 100	70 x 20	220	200	400X8KNO ¹	-SB20	20 mm
			70 x 19				-SB34	3/4"
			70 x 16				-SB58	5/8"
	500 x 6	330 x 125	84 x 25.4	220	200	500X6GRA ¹	-SB10	1"
			84 x 20				-SB20	20 mm
			84 x 19				-SB34	3/4"
	650 x 8	420 x 165	84 x 16	230	200	650X8GRA ¹	-SB58	5/8"
			150 x 25.4				-SB10	1"
			150 x 20				-SB20	20 mm
	650 x 8	420 x 165	150 x 19	230	200	650X8GRA ¹	-SB34	3/4"
			150 x 16				-SB58	5/8"
			150 x 16				-SB58	5/8"



Pneumatic plastic centred wheels

Plastic centred pneumatics with butyl rubber seamless tubes

- Thick sections, large radii, multi-web design for strength (stronger than most imported steel centres).
- Corrosion resistant polypropylene with UV fade protection.
- High engineering standards for wobble-free wheels.
- High quality butyl rubber seamless (butt-joined) tubes.

Bearings

'Deep Groove' shielded bearings (indicated in order codes with a **B**) fitted to a toughened heavy duty housing enables true running and extra strength. Deep groove bearings can last up to 3 times longer than normal pressed bearings. Precision bearings (indicated in order codes with a **Q**) provide ultra-tight tolerances. Roller bearings (indicated with an **R**) are available in 200 x 50.





Tyres

4 ply for longer, rougher life. Many imports use 2 ply.

For wheels pulled or pushed at low speeds (not driven) the tread pattern is not critical. The following are standard. Other patterns can be offered by negotiation.

It is normal for air filled wheels to lose tyre pressure over time even if they are not being used and it's important for your safety that you ensure that the wheels are pumped up to their recommended PSI before use—alternatively you can use our semi-pneumatic puncture proof wheels in applications that require wheels to never go flat.

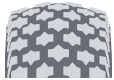
ORDER CODES

Tread	Style	Diameter x tread (mm)	Hub x bore (mm)	Max load (kg) at 8 km/h	Max load (kg) at 15 km/h	Order code	Rim and bearing code	
 Non-marking	200 x 50	200 x 50	60 x 20	75	Not suitable	200X50RIB	-PR20	20 mm
			60 x 12				-PQ12	12 mm
 Non-marking	250 x 4	220 x 54	60 x 20	100	Not suitable	250X4LUG*	-PWB20	20 mm
			60 x 19				-PWB34	3/4"
			60 x 16				-PWB58	5/8"
 Non-marking	250 x 4	220 x 54	60 x 20	100	Not suitable	250X4LGG*	-PWB20	20 mm
			60 x 19				-PWB34	3/4"
			60 x 16				-PWB58	5/8"
 Non-marking	250 x 6	275 x 60	60 x 20	110	Not suitable	250X6IND*	-PWB20	20 mm
			60 x 19				-PWB34	3/4"
			60 x 16				-PWB58	5/8"
 Non-marking	300 x 4	250 x 70	60 x 20	120	Not suitable	300X4DMD*	-PWB20	20 mm
			60 x 19				-PWB34	3/4"
			60 x 16				-PWB58	5/8"
 Non-marking	350 x 4	265 x 70	60 x 20	140	Not suitable	350X4STR*	-PWB20	20 mm
			60 x 19				-PWB34	3/4"
			60 x 16				-PWB58	5/8"
 Non-marking	350 x 6	320 x 80	60 x 20	140	Not suitable	350X6KNO*	-PWB20	20 mm
			60 x 19				-PWB34	3/4"
			60 x 16				-PWB58	5/8"
 Non-marking	400 x 8	400 x 100	105 x 25.4	200	Not suitable	400X8KNO ¹	-PWB10	1"
			105 x 20				-PWB20	20 mm
			105 x 19				-PWB34	3/4"
			105 x 16				-PWB58	5/8"

* Also available with plain bearings, indicated with an **A**, e.g., 250X4LUG-PWA20.

¹ Also available with 1" plain bearing.



Fittings and spares

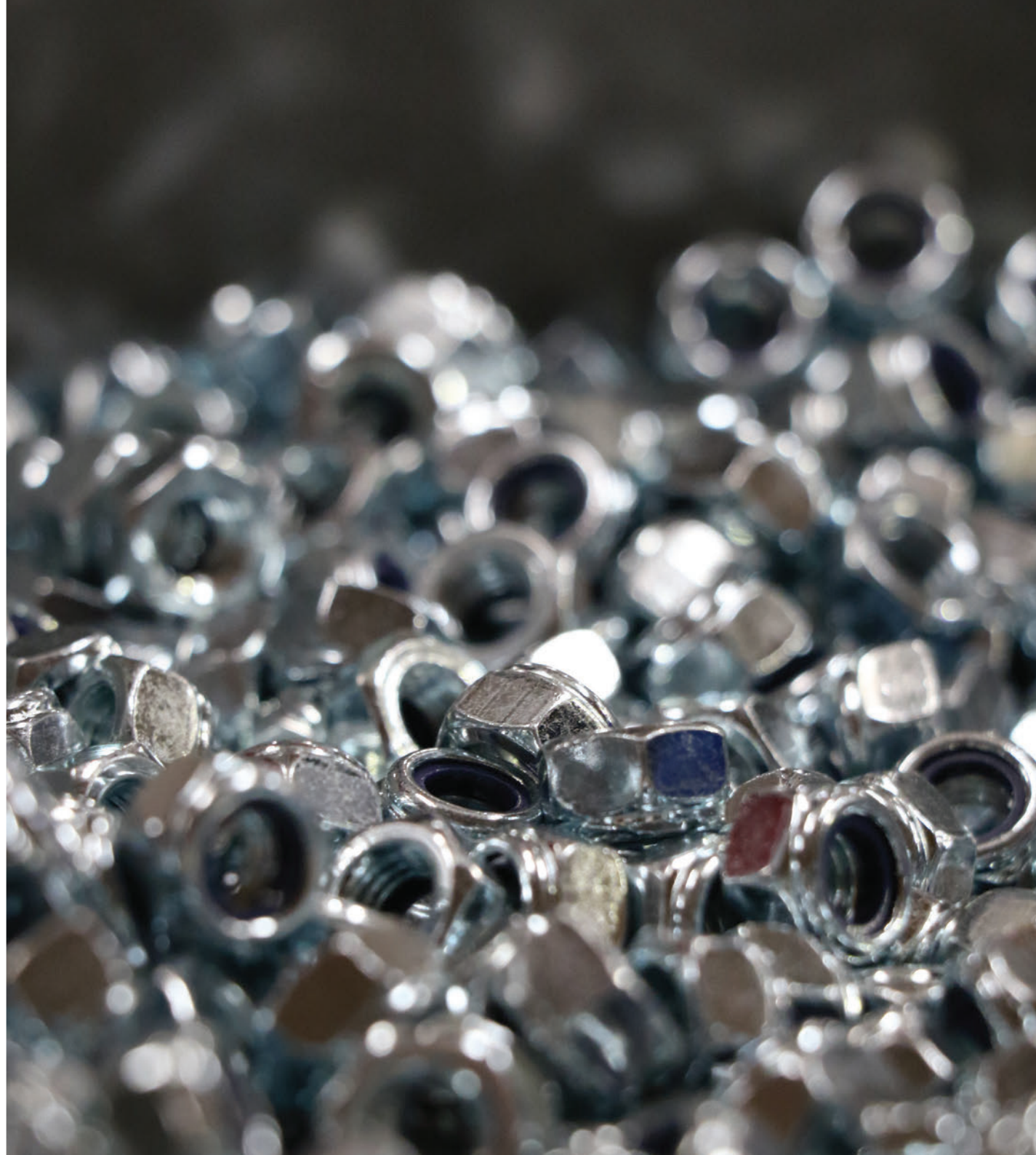

Fittings for 10 mm and 12 mm bolt hole castors

PINTLE BOLTS WITH M10 THREADED TUBE ENDS



Thread x Length	Order code
M10 x 30 mm	SPM10X30ZP
M10 x 40 mm	SPM10X40ZP
M10 x 50 mm	SPM10X50ZP
3/8" x 19 mm	SP3/8X19ZP
3/8" x 30 mm	SP3/8X30ZP
3/8" x 40 mm	SP3/8X40ZP
3/8" x 50 mm	SP3/8X50ZP

3/8" FITTINGS



Description	Order code
Drill a 12 mm (1/2") hole through the base and fit this down from the top, and screw the castor up into it through a washer.	38WTEE



The base must be 3 mm (1/8") thick, or washers of at least 25 mm (1") OD used on both side to spread the load.	38WNUT
--	--------



Fits horizontal 1" x 1.6 square tube. Holds a 3/8" Whit nut in position 32 mm along a horizontal tube.	ENDPLUG25
--	-----------

GRIP-NECK PINTLES (FITS L, K & M SERIES)



Description	Order code
For L series, M10 grip neck pintles are supplied loose to be retro-fitted. Size: 8 mm OD x 39 mm	-GN
For K & M series, M12 grip neck pintles are supplied loose to be retro-fitted. Size: 8 mm OD x 39 mm	-GNKM

GRIP-NECK PINTLE ADAPTERS



Shape	Material	Adapter size (mm)	Tube size ID	OD	Wall	Order code
Round	Nylon	11	10.9	12.7	0.9	S11
Round	Nylon	14	13.6	16.0	1.2	S14
Round	Nylon	17	16.6	19.0	1.2	S17
Round	Nylon	17	16.6	19.0 SQ	1.2	S17SQ
Round	Nylon	19	19.0	22.2	1.6	S19
Round	Nylon	23	23.0	25.4	1.2	S23
Round	Nylon	23	23.0	25.4 SQ	1.6	S23SQ

Fittings for 12 mm bolt hole castors

PINTLE BOLTS



Thread x Length	Order code
M12 x 81 Standard	-E
M12 x 65 Stainless Steel	-ESS
M12 x 35	-E12x35
M12 x 40	-E12x40
M12 x 45	-E12x45
M12 x 50	-E12x50
M12 x 55	-E12x55
M12 x 65	-E12x65
1/2" UNF x 1 1/8"	-E1/2x30
1/2" UNF x 1 9/16"	-E1/2x40
1/2" UNF x 2"	-E1/2x50

EXPANDING ADAPTERS (suits tubing <28 mm)

Shape	Material	Size (mm)	Tube size ID range	Mild Steel	Stainless Steel
Round	Nylon	19	18.5–21.0	-ER19	-ER19SS
Round	Nylon	22	21.5–24.0	-ER22	-ER22SS
Round	Rubber	22	21.5–24.0	-ER22R	-ER22RSS
Round	Nylon	28	25.0–28.0	-ER28	-ER28SS
Square	Nylon	19	18.5–21.0	-ES19	-ES19SS
Square	Nylon	22	21.5–24.0	-ES22	-ES22SS
Square	Rubber	22	21.5–24.0	-ES22R	-ES22RSS
Square	Nylon	28	25.0–28.0	-ES28	-ES28SS



SOLID NYLON PINTLES

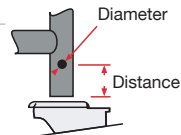
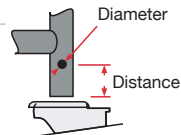

Description	Stem OD	Tube size (OD x wall)	Cross drill hole (distance from end x diameter)	Order code
NDL AND GENERAL CASTORS Includes 2 x inset nuts, 2 x washers, 2 x coach bolts, 1 x M12 x 60 bolt, 1 x M12 Nyloc nut	22 mm round	25 x 1.6 mm		19 x 6 mm
	28 mm round	32 x 1.6 mm		19 x 8 mm
TRINITY Excludes nut	22 mm round	25 x 1.6 mm		19 x 6 mm
	28 mm round	32 x 1.6 mm		19 x 8 mm

SOLID STEEL PINTLES

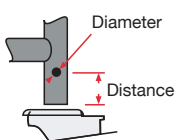

Stem OD	Tube size (OD x wall)	Cross drill hole (distance from end x diameter)	Order code	
19 mm round	22 x 1.2 mm		-AR19Z	
22 mm round	25 x 1.6 mm		-AR22Z	
-AR19 with adapter 22 mm square	25 x 1.6 mm SQ		19 x 8 mm	-AS22Z
28 mm round	32 x 1.6 mm		19 x 8 mm	-AR28Z

REDUCING BUSHES



Description	Order code
Convert 12 mm bolt hole to 10 mm	SPRB1/2-10
Convert 12 mm bolt hole to 8 mm	SPRB1/2-8

SQUARE THREADED TUBE ENDS (suits tubing >28 mm)



Order code (includes M12 x 75 mm set screw, zinc plated)	Order code (includes M12 x 75 mm set screw, stainless steel)	Order code (spare part excluding set screw)	Suits tube size (mm)
-TTESQ25Z	-TTESQ25S	SP-TTESQ25	25 x 25 square (1.6–2.5 wall)
-TTESQ32Z	-TTESQ32S	SP-TTESQ32	32 x 32 square (1.6–2.5 wall)
-TTESQ38Z	-TTESQ38S	SP-TTESQ38	38 x 38 square (1.6–2.5 wall)
-TTESQ50Z	-TTESQ50S	SP-TTESQ50	50 x 50 square (1.6–2.5 wall)

Order codes for set screws: SPM12X75SETZ (zinc plated), SPM12X75SETS (stainless steel)

Spares for pneumatic wheels and general wheels

TUBES—BUTYL RUBBER SEAMLESS



Description	Order code
Tube Pneumatic 200 x 50	SPTUBE200X50
Tube Pneumatic 250 x 4	SPTUBE250X4
Tube Pneumatic 300 x 4 or 350 x 4	SPTUBE300/350X4
Tube Pneumatic 250 x 6	SPTUBE250X6
Tube Pneumatic 350 x 6	SPTUBE350X6
Tube Pneumatic 500 x 6	SPTUBE500X6
Tube Pneumatic 400 x 8	SPTUBE400X8
Tube Pneumatic 650 x 8	SPTUBE650X8

RIMS—PLASTIC



Description	Order code
PLASTIC RIM 200 x 50 suits 200X50 with roller bearing	SPRIM200X50PRNB
PLASTIC RIM 200 x 50 suits 200X50 with precision bearing	SPRIM200X50PQNB
PLASTIC RIM 4 x 175 suits 250/300/350 x 4, no bearing	SPRIM4X175PW(NB)
PLASTIC RIM 6 x 200 suits 250/350 x 6, no bearing	SPRIM6X200PW(NB)
PLASTIC RIM 8 x 250 suits 400 x 8, no bearing	SPRIM8X250PW(NB)

BEARINGS



Description	Order code
B—Deep groove ball bearing 1/2" (12.7 mm) ID	SPBRGC05
B—Deep groove ball bearing 1" (25.4 mm) ID	SPBRGC10
B—Deep groove ball bearing 20 mm ID	SPBRGC20
B—Deep groove ball bearing 3/4" (19.05 mm) ID	SPBRGC34
B—Deep groove ball bearing 5/8" (15.88 mm) ID	SPBRGC58
Q—Precision ball bearing #608 5/8" (15.88 mm) ID	SPBRGQ6004X58
Q—Precision ball bearing #6205 2RS suits CFQ Wheelchair, 8 mm ID	SPBRGQ6082RS
Q—Precision ball bearing 12 mm bore (suitable for pneumatics)	SPBRGQ6205X01
Q—Precision ball bearing #6004 20 mm	SPBRGQ6004X20
Q—Precision ball bearing #6004 3/4" (19.05 mm) ID	SPBRGQ6004X34
Q—Precision ball bearing #6005 25 mm ID	SPBRGQ6005X25
Q—Precision ball bearing with seals #6202 2RS, 15 mm ID	SPBRGQ6202X15
Q—Precision ball bearing #6204 2RS, 20 mm ID	SPBRGQ6204X20
Q—Precision ball bearing 1" (25.4 mm) ID for 400X8 pneumatic	SPBRGQPNEU01

HOUSING AND REDUCING BUSHES



Description	Order code
Housing (nylon) for a #6004 Q ball bearing	SPHOUSING6004
Housing (nylon) FLANGED to suit a #6004 Q ball bearing	SPHOUSING6004FLG
Housing (nylon) FLANGED to suit a #6204 Q ball bearing	SPHOUSING6204
Reducing Bush FLANGED (nylon) 1" to 20 mm ID, 20 mm L—Grey	SPBSH10-20
Reducing Bush FLANGED (nylon) 1" to 3/4" ID Flange, 20 mm L—Black	SPBSH10-34
Reducing Bush FLANGED (nylon) 1" to 5/8" ID Flange, 20 mm L—Black	SPBSH10-58
Reducing Bush FLANGED (nylon) to suit a 5/8" deep groove ball bearing (SPBRGC58), 5/8" to 1/2"	SPRB58-1/2

TYRES



Description	Order code
Pneumatic 200 x 50 RIB tread	SPTYRE200X50RIB
Pneumatic 250 x 4 LUG tread	SPTYRE250X4LUG
Pneumatic 250 x 4 LGG tread	SPTYRE250X4LGG
Pneumatic 250 x 6 IND tread	SPTYRE250X6IND
Pneumatic 300 x 4 DMD tread	SPTYRE300X4DMD
Pneumatic 350 x 4 STR tread	SPTYRE350X4STR
Pneumatic 350 x 4 ZGG tread	SPTYRE350X4ZGG
Pneumatic 350 x 6 KNO tread	SPTYRE350X6KNO
Pneumatic 400 x 8 KNO tread	SPTYRE400X8KNO
Pneumatic 400 x 8 HWY tread	SPTYRE400X8HWY
Pneumatic 500 x 6 GRA tread	SPTYRE500X6GRA
Pneumatic 650 x 8 GRA tread	SPTYRE650X8GRA



General spares

AXLES, NUTS AND BOLTS



Description	Order code
Axle to suit VHD X Series (bolt & nut)	SPAXLEX
Axle to suit VHD V Series (bolt & nut)	SPAXLEV
Axle to suit CFQ Wheelchair castors Zinc plated bolt & nut	SPAXLECFQ
Axle to suit M Series, stainless steel (bolt & nut)	SPAXLEMSSBOLT
Axle to suit H Series (bolt & nut)	SPAXLEH
Axle to suit Y Pneumatics (bolt & nut)	SPAXLEHPNEU
Axle to suit H Series, stainless steel (bolt & nut)	SPAXLEHSS
Axle to suit J Series (bolt & nut)	SPAXLEJ
Axle to suit K Series (bolt & nut)	SPAXLEK
Axle to suit M Series (bolt & nut)	SPAXLEM
Axle to suit M Series, mild steel (Chicago Screw)	SPAXLEMCHICAGO
Axle to suit M Stainless Steel (Chicago Screw)	SPAXLEMSSCHICAGO
Axle to suit O Series forks (bolt & nut)	SPAXLEO
M8X12 Cup head bolt	SPBOLTM8CUPHEAD
M8X1.25 Pitch conelock nut	SPNUTM8CONE

SPACERS



Description	Order code
H Series Spacer 61 mm L x 20 mm OD x 12.7 mm (1/2") ID	SPSPACERH
H Series Spacer 61 mm L x 20 mm OD x 16 mm ID (5/8")	SPSPACERH(16)
H Series Spacer 61 mm L x 19 mm OD x 12.7 mm (1/2") ID	SPSPACERH(19)
H & O Series Spacer 61 mm L x 20 mm OD x 13 mm ID	SPSPACERROSS
H & O Series Spacer—top hat (set of 2) 61 mm x 20 mm OD x 12.7 mm (1/2") ID	SPSPACEROTOPHAT
Special J Series Spacer 46 mm L x 20 mm OD x 1/2" ID	SPSPACERJ(05)R
J Series Spacer to suit plain bearings 46 mm L x 1/2" OD x 10 mm ID	SPSPACERJA
J Series Spacer to suit roller bearing 46 mm L x 20 mm OD x 10 mm ID	SPSPACERJR
J Series Spacer 46 mm L x 1/2" OD x 10 mm ID	SPSPACERJSS
K Series Spacer	SPSPACERK
M Series Spacer 41 mm L x 12 mm OD x 8 mm ID	SPSPACERM
M Series Spacer—stainless steel 36 mm L x 12 mm OD x 8 mm ID	SPSPACERMSS

BEARINGS AND BUSHES



Description	Order code
R—Roller bearing for H Series, 20 mm ID, stainless steel	SPBRGH20SS
B—Deep groove 1/2" (12.4 mm) for PRB (also suits GPBO)	SPBRGPRB05
Q—Precision bearing for M Series 608	SPBRGMQ608ZZ
Q—Precision bearing for M Series 608, stainless steel	SPBRGMQ608ZZSS
Q—Precision bearing for K series 608, twin seal	SPBRGKQ608NG
R—Roller bearing for J series, 20 mm ID	SPBRGJC20
R—Roller bearing for H Series, 20 mm ID	SPBRGR20
R—Roller bearing for J Series, 20 mm ID, stainless steel	SPBRGR20JSS
Sleeve for H Series roller bearing	SPBRGR20SLEEVE
R—Roller bearing, 3/4" bore for H, R and N Series	SPBRGR34

THREAD GUARDS (SET OF 2)



Description	Order code
Thread guard set—KSP75	SPTGDKSP75Z
Thread guard set—PR Wheels	SPTGDGHUBCAP
Thread guard set—HB & HS 200	SPTGDHB200SET
Thread guard set—HU 200	SPTGDHU200SET
Thread guard set—KUQ100	SPTGDKUQ100SET
Thread guard set—MNN100	SPTGDMNN100SET
Thread guard set—MNN75	SPTGDMNN75SET
Thread guard set—JBA100/125	SPTGDJB100
Thread guard set—JUR100	SPTGDJUR100
Thread guard set—JUR125	SPTGDJU125SET
Thread guard set—MSQ	SPTGDMSQSET
Thread guard set—KJA75	TGDKJ75GRY

PLATES



Description	Order code
H & O ISO top plate raw	SPPLATEHISORAW
H & O NA top plate raw	SPPLATEHNARAW
Flat spacer plate 96 mm x 78 mm	SPPLATEMISO
Flat spacer plate 96 mm x 78 mm Stainless Steel	SPPLATEMISOSS

BUFFERS—D SECTION (HOLLOW)



Description	Order code
Normally placed around the edges of the trolley (between corner buffers) to prevent damage to door jambs. These are fitted by pushing a (off-cut) metal strip along the centre of the section and screwing through into the side of the trolley. The head of the screw will pop through the outer rubber leaving a small hole. If the strip is to be fitted on a rounded corner, this should be of at least 50 mm radius to prevent buckling of the strip.	D25SPOOL Length per spool: 80 m
	D25BAG Length per bag: 8 m

BUFFERS—CORNER



Description	Order code
Corner buffers can be fitted to new or existing trolleys with square corners, reducing damage to walls and door jambs. They are fitted by four pan head self tappers, which are recessed down inside each arm of the buffer (No. 10 x 1" or similar). Being made from TPE they are very resistant to abrasion and chemicals. The end profile is matched to the 'D' section rubber strip.	CB8025

BUFFERS—LEG



Description	Order code
ROUND TPE These are used to prevent damage to corridor walls. The buffers are placed onto tubular legs just before the castors. When a trolley approaches a wall the buffers make contact first and freely revolves on the tubing, thus rolling the trolley along the wall so it causes no damage. In the case of 25.4 mm square tubing the urethane buffers are supplied with a 32 mm hole, together with a 'dress-cap' with a 25.4 mm square inner and a 32 mm round outer.	BJ100X25 Suit 25.4 mm round tubing OD
	BJ100X32 Suit 32 mm round tubing OD
	BJ100X25SQ Suit 25.4 mm square tubing OD
	BJ125X25 Suit 25.4 mm round tubing OD
	BJ125X32 Suit 32 mm round tubing OD
	BJ125X25SQ Suit 25.4 mm square tubing OD
	BJDC25 Black dress cap to suit 25.4 mm square tubing OD



Tugs and Movers



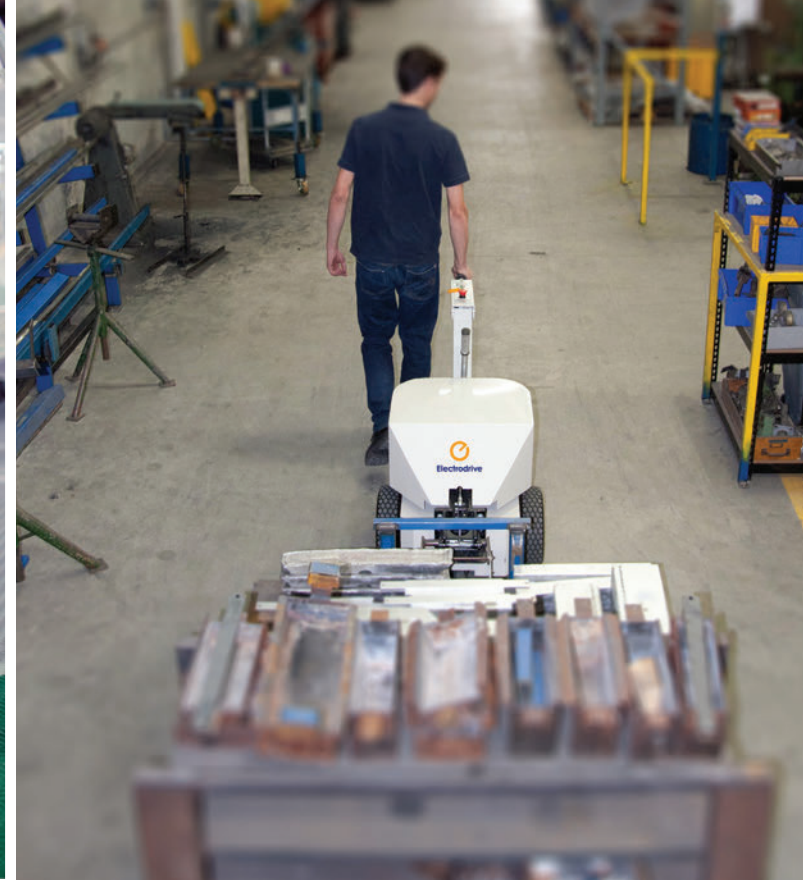
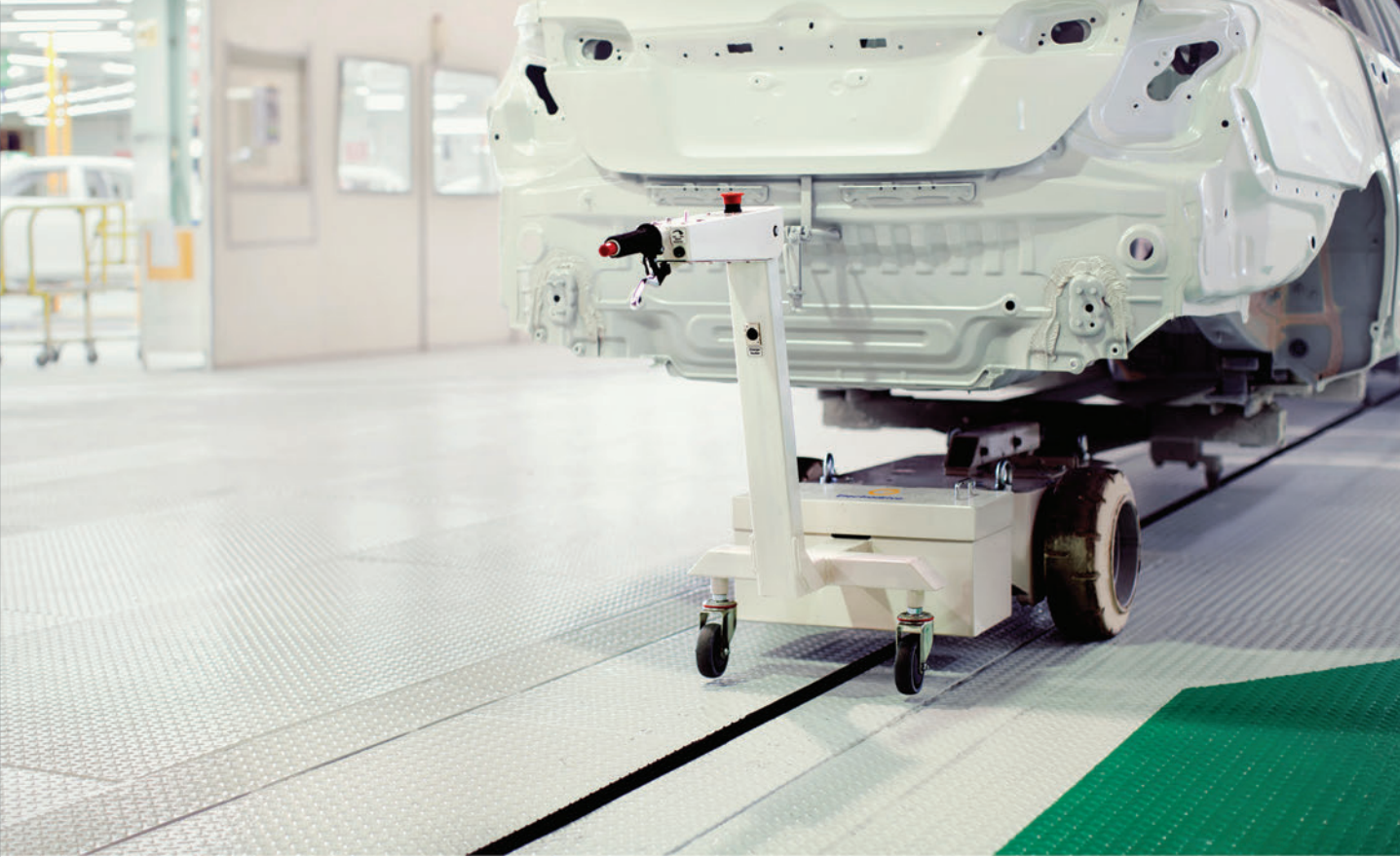

Move equipment safely with Electrodrive Tugs and Movers

Safe

Pushing and pulling heavy loads in the workplace increases the risk of injury to the person moving the load. Furthermore, the risk of collision with other people or objects can result in expensive medical and/or damage bills. Using a Powered Tug or Mover can help you and your staff move carts, trolleys and equipment safely by maximising forward vision, reducing the risk of collisions and the risk of back and side strains.

Simple

Driving a Tug or Mover is simple. Unlike a forklift, no license is required to operate one, and it can be used in small confined spaces. With a range of hitches available, it is easy to customise one for your existing trolleys.

Strong

A Tug or Mover can comfortably tow up to 500 kg for the smallest model. Other models are available that can tow up to 20 tonnes with a single operator.

Quiet

All Tugs and movers are battery powered, so they are smooth, quiet and operate with zero emissions.

Choosing a Tug or Mover

1 Determine the weight and incline of the load being moved

The nominal towing capacity of our tugs relates to the weight that can be pulled on a flat surface (with a friction coefficient of 0.5 such as dry concrete or bitumen).

The practical rule of thumb to determine which tug is right for your application is to get the pull force (in kilograms) required to start your load moving (on the worst case surface of your application) and multiply it by 40. This will give you the towing force.

So, for example, if it takes 20 kg of pull force to get your trolley moving on your intended surface, multiply this by 40 to get a towing force of 800 kg, meaning that you will require a Tug that can pull more than the Tug Compact (500 kg), and would need the power of a Tug Evo 1 Tonne, which will exceed your pull force comfortably.

Measuring the pull force required to start the load moving can be done with a weight scale—of the type used to weigh produce at the green grocers, or the more modern digital luggage scales such as those shown in the photos above.

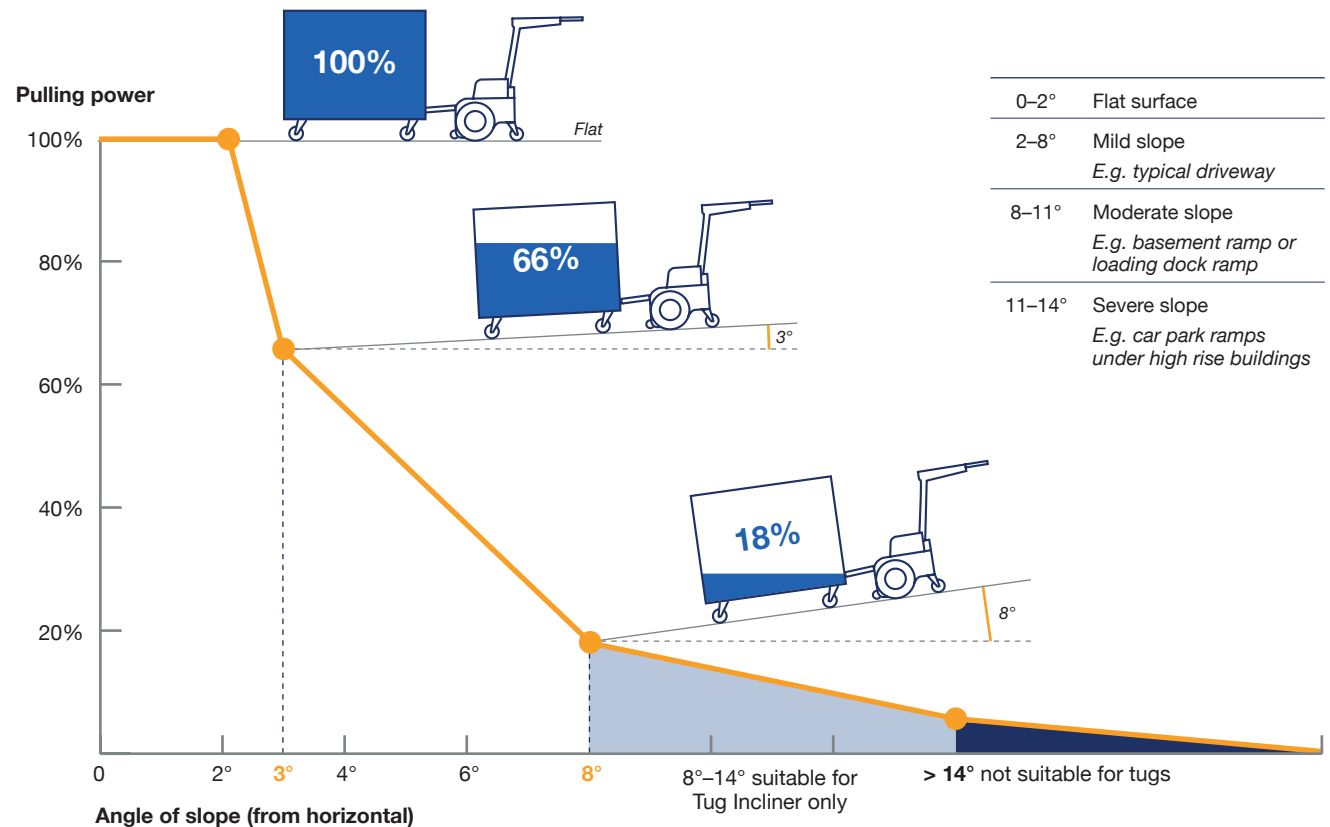

It is important to measure the pull force required on the worst case of your application. Perhaps a linen cart will need to follow a route that includes the flat internal hospital passageways on carpet, as well as an outside bitumen area with a 6 degree slope. Make sure you measure the worst case scenario—in this example, the outside inclined area when wet (to simulate the added slipperiness that occurs when raining).

A final ‘top tip’: measuring the incline can be done with a smart phone app. Go to your app store and search for “measure incline” or “measure slope” or “spirit level” and you’ll have many options to choose from for both Apple and Android smart phones.





2 Determine whether it will be used in confined spaces

Suitable for confined spaces

	Tug Compact	Very small footprint and turning circle
	Tug Evo 1T and 2T	Ideal for moving heavy weights from 1–3.5 Tonnes
	Tug Classic 3.5T	
	Tug Incliner	Excellent for ramps such as steep basement driveways
	Gzunda Bed Movers	Perfect for navigating hospital corridors
	Transpak Powered Trolley	Great for moving multiple small objects

Suitable for open spaces

	Tug Incliner	Excellent for ramps and outdoor terrain
	Tug Classic 5T	Perfect for moving very heavy loads over 3.5 Tonnes, and up to 20 Tonnes
	Tug Tough 10T and 20T	

3 Determine if the load will have existing hitch points

Hitches to suit the most popular trolleys



Hitches that adapt to different trolley designs



4 Determine the load's wheel configuration

Castor configuration will affect towing

Four swivel castors will not trail properly behind the towing unit – they will cut corners rather than follow the unit. They will also tend to ‘whip’ – to over correct any sideways displacement and sway from side-to-side as they travel.

These problems become more acute if more trolleys are linked in a train. We offer fixed wheel skate hitch (pictured) accessories to correct this problem for situations where it's not feasible to replace two of the four swivel castors on an existing trolley fleet.



If two fixed castors are used at the rear of the trolley it eliminates the whip, and improves trailing and towing.

An ideal configuration is to mount 2 swivel castors 1/6 of the length of the trolley from the front of the trolley and two fixed castors 1/3 of the length of the trolley from the rear. This gives little whip, and good trailing. Note though, that such trolleys should not have a heavy load concentrated at the rear end or they will tip backwards.

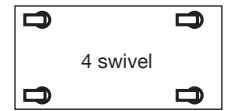
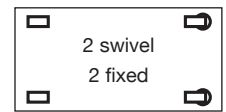
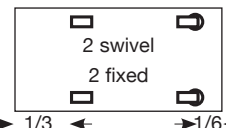
DIRECTION OF TRAVEL →	Trailing	Whip	Stability
 <p>4 swivel</p>	Poor	Bad	Very good
 <p>2 swivel 2 fixed</p>	Good	Least	Very good
 <p>2 swivel 2 fixed</p> <p>→ 1/3 ← → 1/6 ←</p>	Good	Little	Good

Powered Tugs



Tug Compact

- 500 kg tow capacity
- Compact and easy to manoeuvre in tight corridors
- Wide variety of hitches available

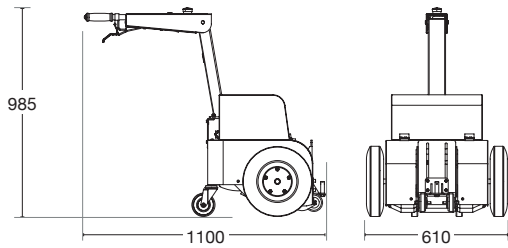

Order Code

Tug Compact 500 kg

TUGCOMPACT500



Tug Evo 1T and 2T

- Tow up to 2 tonnes safely
- Compact and easy to manoeuvre in tight corridors
- Wide variety of hitches available

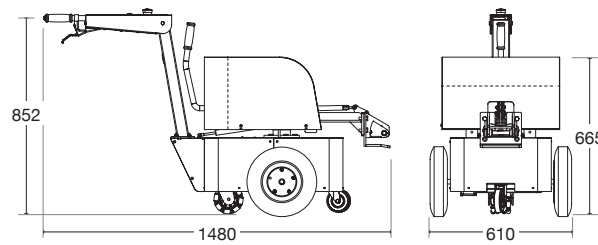

Order Code

Tug Evo 1 Tonne

TUGEVO1T

Tug Evo 2 Tonne

TUGEVO2T



Tug Classic 3.5T and 5T

- Tow up to 5 tonnes safely
- Compact and easy to manoeuvre in tight corridors
- Wide variety of hitches available

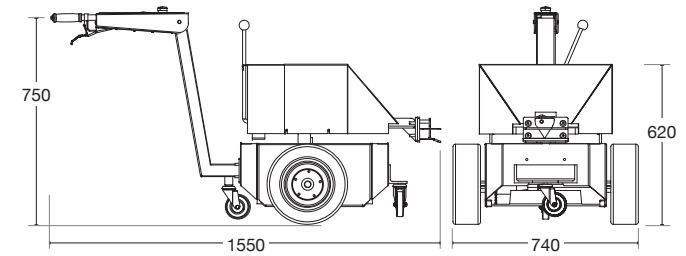

Order Code

Tug Classic 3.5 Tonne

TUGCLASSIC3.5T

Tug Classic 5 Tonne

TUGCLASSIC5T



Tug Incliner

- Based on the Tug Classic, tow up to 1 tonne safely on ramps or slopes
- 1 tonne (on 8° incline), or 500 kg (on 14° incline) towing capacity
- Suitable for high rise basements, large factories or caravan parks
- Wide variety of hitches available

	Order Code
Incliner Tug (includes one ballast plate)	TUGINCLINER1T



Tug Tough 10T and 20T

- Tow up to 20 tonnes safely
- Heavy duty construction, perfect for pulling very heavy equipment, vehicles and aircraft
- Wide variety of manual or automated hitches available

	Order Code
Tug Tough 10 Tonne	TUGTOUGH10T
Tug Tough 20 Tonne	TUGTOUGH20T
Beeping reversing light	EDEL1080F
Amber strobe light	EDEL1000F

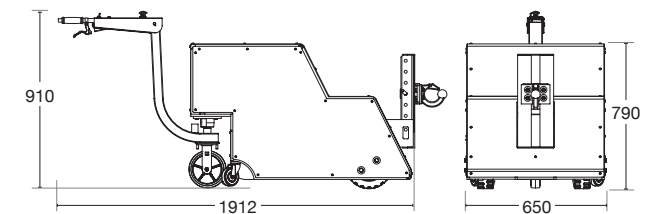

Tug Tough 10 Tonne

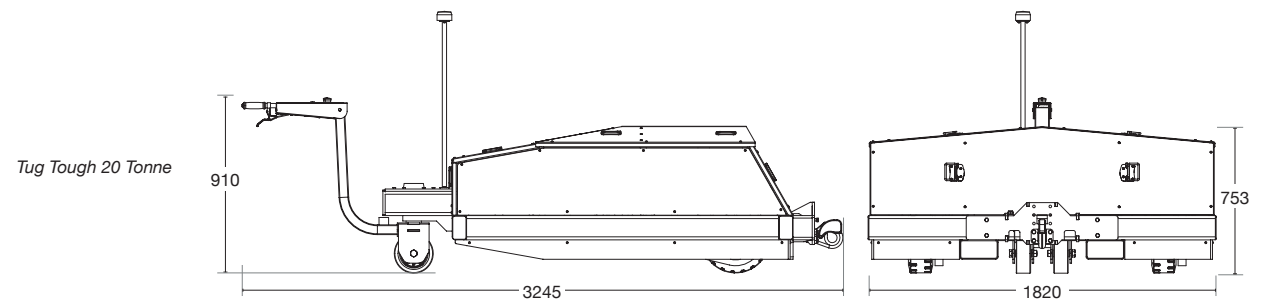

Tug Tough 20 Tonne



Moving hospital beds

Safe moving in Hospitals and Aged Care

Moving beds through high traffic departments in hospital corridors, in and out of lifts, increases the risk of a manual handling injury. Simplify the task safely and smartly with a Gzunda Bed Mover.

With the capacity to move up to 600kg, Gzunda Bed Movers enable a single operator to efficiently manoeuvre a fleet of hospital beds in your healthcare facility with minimal effort.

Improving the safety of bed moving within your facility

The Gzunda's easy-to-use controls include a key switch, twist grip throttle, variable speed control, horn and emergency stop button.

All Gzunda Bed Movers come with a standard flex hitch. This hitch provides maximum compatibility with the majority of hospital beds in use today. Using a simple retractable strap and buckle arrangement, the flex hitch enables hospital beds to be quickly and easily attached. We can also easily customise a hitch to suit a variety of hospital bed frames if required.

Bed movers are:

- Easy to use
- Quiet to operate with zero emissions
- Easy to drive with no license required
- Covered by a comprehensive 12 month warranty

Bed Movers



Gzunda GZS

- 600 kg capacity
- No under-bed clearance required
- Comprehensive 12 month warranty

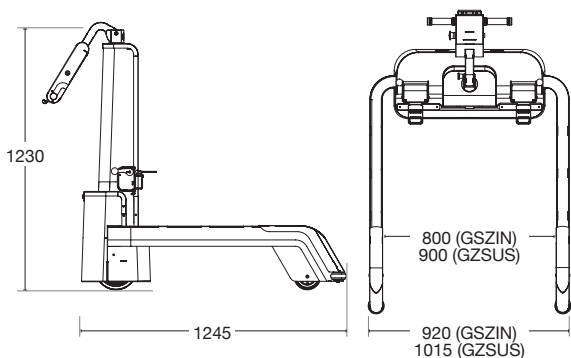

Order Code

Gzunda Bed Mover 600 kg split tyne (International)

GZSIN(NH)*

Gzunda Bed Mover 600 kg split tyne (US)

GZSUS(NH)*



Gzunda GZ10SL

- 500 kg capacity
- Compact and easy to manoeuvre in tight corridors
- Requires 100mm of clearance under the bed (can be modified to 90mm if required)

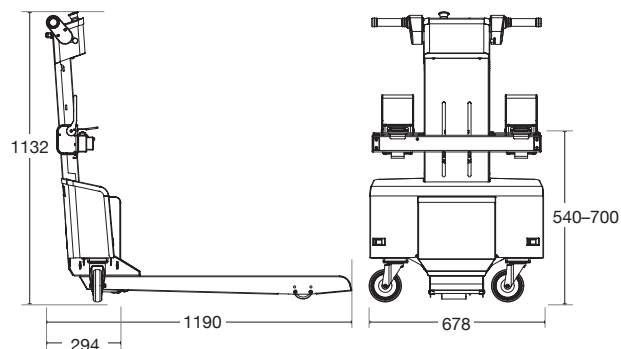

Order Code

Gzunda Bed Mover 500 kg

GZ10SL(NH)*

* NH: Bed Movers are sold without a hitch. Hitches are sold separately to suit the range of bed models in your fleet. See the Electrodrive website for more details.



Gzunda GZS



Gzunda GZ10SL



Moving linen

Moving linen safely

Moving linen trolleys manually can be a work safe concern. Soiled linen can be very heavy and many linen trolleys restrict the line of sight when pushed from behind. Pulling one or more trolleys using a powered linen mover dramatically improves safety and productivity, especially in tight corridors and hallways.

Linen Movers are:

- Quiet to operate with zero emissions
- Easy to drive with no license required
- Covered by a comprehensive 12 month warranty

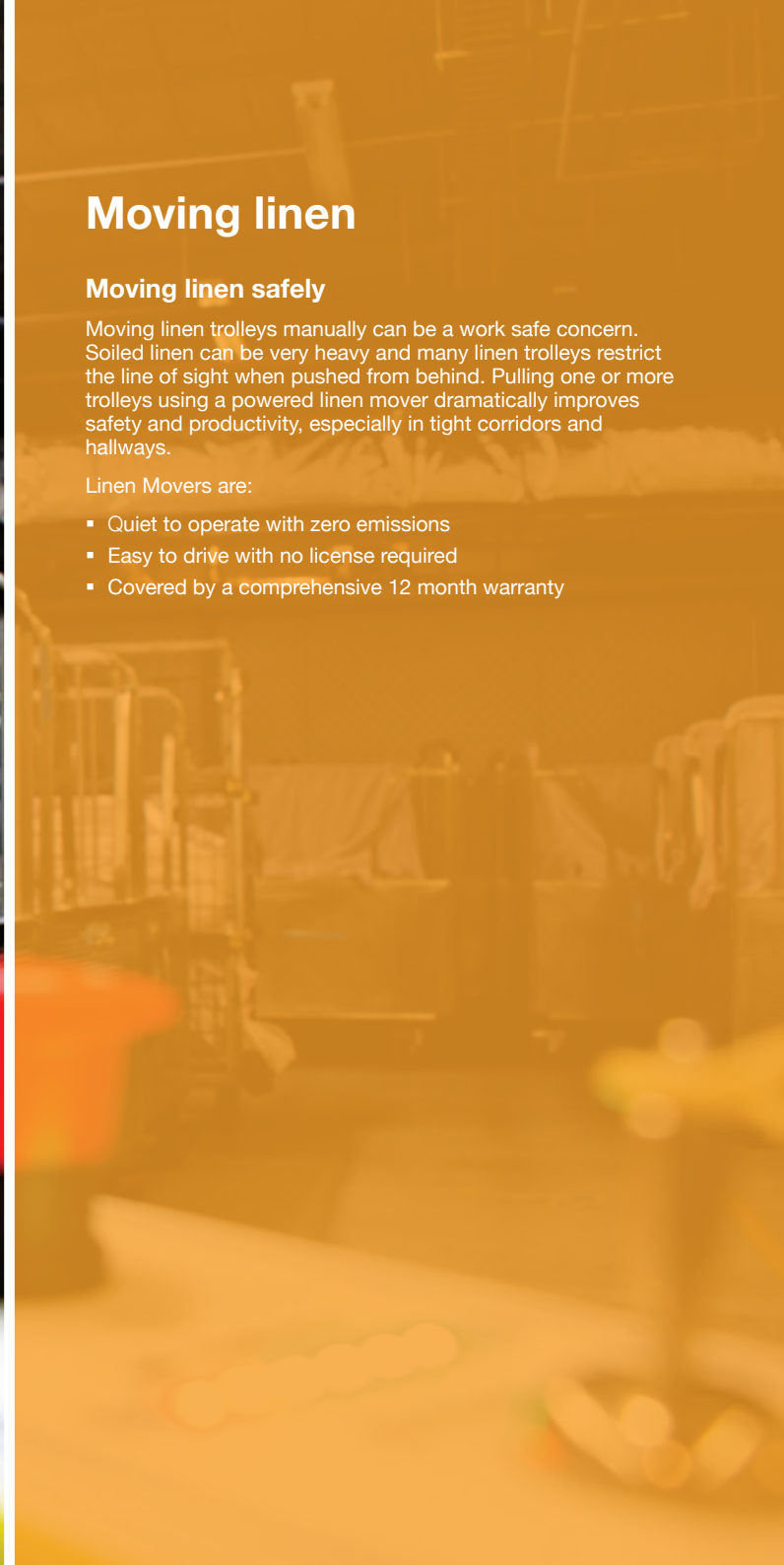

Linen Movers



Gzunda Linen Mover

- 500 kg towing capacity
- Compact and easy to manoeuvre in tight corridors
- Middle tyne makes this linen mover ideal for towing linen trolleys fitted with four swivel castors
- Supplied with clamping hitch

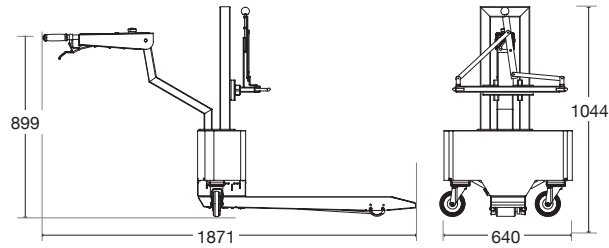

Order Code

Gzunda Linen Mover 500 kg

GZLINENMOVER



Tug Compact Linen Mover

- 500 kg towing capacity
- Compact and easy to manoeuvre in tight corridors
- Supplied with clamp hitch
- Ideal for towing linen trolleys fitted with two swivel and two fixed castors

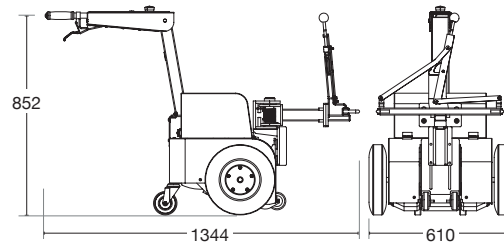

Order Code

Tug Compact Linen Mover 500 kg

TUGLINENMOVER





Meal delivery

Pushing tall trolleys from behind can block your line of sight. Front of load towing with a Transpak Powered Trolley helps avoid collisions by ensuring a clear view of what's ahead.

Designed for meal system movers, this powerful machine will help your staff manoeuvre tight hallways and blind corners with ease, certain that they won't be colliding with patients, medical equipment, or medical staff.

Meal system movers are:

- Quiet to operate with zero emissions
- Easy to drive with no license required
- Covered by a comprehensive 12 month warranty

Meal System Movers



Transpak Powered Trolley

- 500 kg tow capacity
- Compatible with all meal delivery systems including those from *Burlodge, Socamel and Versigen*
- Can be optioned with non marking tyres
- Frame size can be built to suit your requirements
- Comprehensive 12 month warranty

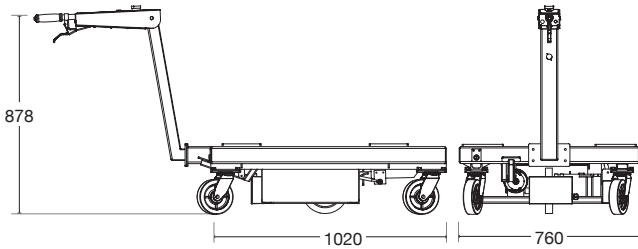

Order Code

Powered Meal System Mover 500 kg	TRANSPAK500
----------------------------------	-------------

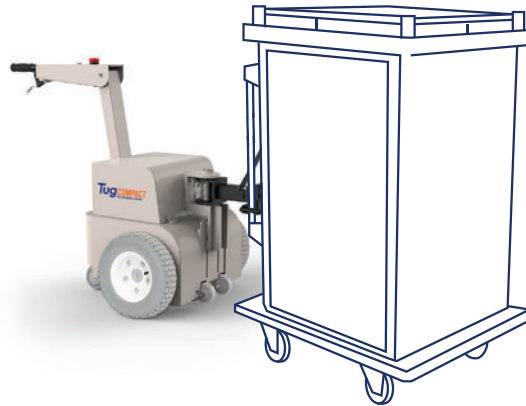

Tug Compact

- 500 kg tow capacity
- Customised hitch to suit all pod and mobile meal delivery systems*
- Compact and easy to manoeuvre in tight corridors

Order Code

Tug Compact 500 kg	TUGCOMPACT500
--------------------	---------------

* Hitch shown is for illustration purposes only.



Transpak Powered Trolley

Powered Fifth Wheel



The powered wheel assembly with battery



Control cable



The fully adjustable tiller handle and arm, with three speed settings, forward and reverse direction control, emergency stop, and back-off buttons

Turn any trolley into a powered trolley

Electrodrive's Powered Fifth Wheel is a retrofittable solution for converting your manually pushed trolleys into powered ones. Controlled with an ergonomically designed tiller arm for a natural walking posture, the powered fifth wheel works with your trolley's other four wheels to help you move heavy loads safely and efficiently.

The Powered Fifth Wheel kit

1. A powerful motorised wheel capable of moving up to 500 kg
2. An adjustable tiller arm that can be easily reconfigured to fit vertical or horizontal handles of varying widths and heights. It can also be folded away for a smaller footprint, for elevators and tight spaces
3. A flexible control cable

Features

- 500kg tow capacity
- Stay in 'front of load', preventing push-pull injuries and the risk of pedestrian collision
- Tiller arm with three speed control settings, as well as forward and reverse
- Non marking tyre suitable for indoor use
- Powered by a 24 V gel cell batteries
- Includes smart charger
- Compatible with Fallshaw O Series 200 mm castors (installation height 241 mm)

	Order Code
Motorised wheel	P5W500
Tiller arm	P5WTILLER
Control cable—2.8 m	P5WCABLE2.8



Configured for horizontal handle bars



Configured for vertical handle bars

Many trolleys, one solution

The handle clamps on both ends of the tiller arm can be fully customised, ensuring compatibility with a wide variety of vertical or horizontal trolley handles, including those found on:

- Meal delivery systems
- Hotel luggage trolleys
- Stock trolleys
- Linen trolleys

MOVE FROM THIS

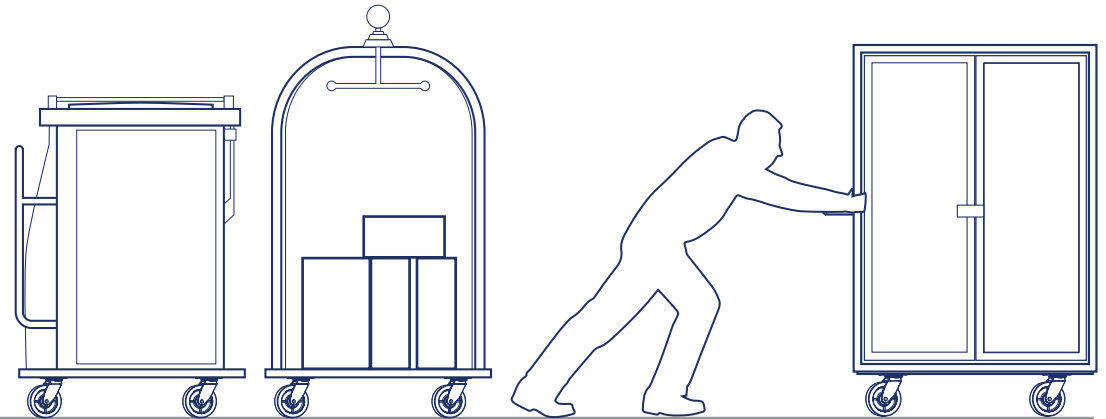

TO THIS

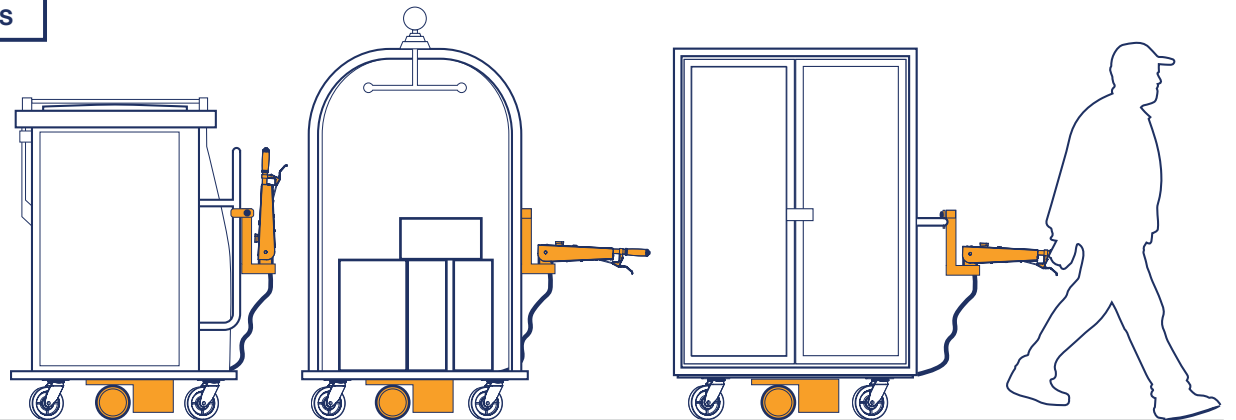



Bin Lifters





There will always be waste. A growing population means an increase in rubbish, and more rubbish means an increase in manual waste handling processes like emptying wheelie bins into industrial bins or skips.

While some workplaces previously allowed manual lifting of wheelie bins into skips, the rising costs of workplace injuries has meant a major change is being implemented across Australia and the rest of the world.

In their *Waste Management Health and Safety Fact Sheet, June 2014*, the Queensland Department of Education and Training acknowledged this growing problem by directing that:

'Wheelie bins are not to be manually lifted into industrial bins.'

'If wheelie bins are to be emptied into an industrial bin then an appropriate lifting device is to be provided.'

If your workplace still has a manual waste handling problem, it's time to find a solution.

Our range of full swing or lift-and-tilt Liftmaster bin lifters allow a single operator to lift and empty wheelie bins safely, whilst

eliminating the risk of back and side strains caused by lifting heavy bins above shoulder height.

Full swing bin lifters

Full swing bin lifters employ gas struts or hydraulic cylinders to swing the bin upwards into a tilt position. From the entry level *Niftylift*, with its assisted lift function up to 30 kg, to the spark-free hydraulic hand pump *Rugged Manual*, and it's electro-hydraulic sibling, the *Rugged Powered*, lifting up to 150 kg, these bin lifters are light, strong and rugged, ideal for being moved around uneven surfaces in construction sites and other controlled industrial environments.

Full swing bin lifters are:

- light weight
- easily manoeuvrable
- require a high ceiling height
- not suitable for use with pedestrian traffic nearby

Lift-and-tilt bin lifters

For environments like schools, businesses, event centres, retail outlets, basement car parks, or any other areas where pedestrian traffic is likely, the Liftmaster range of lift-and-tilt bin lifters provide the ideal solution. From the entry level *Ecolift*, with safety cage panels to protect the operator from moving parts, to the simple push-button safety of the *Simplicity Plus*, all the way to fully caged design of the *Universal*, these bin lifters have been cleverly engineered to keep both the operator and bystander safe.

Lift-and-tilt bin lifters:

- have a large and stable footprint
- can operate with low ceiling heights
- prevents injury to pedestrians with it's contained lift action

Liftmaster Bin Lifters

Niftylift

- Full swing bin lifter, lifts up to 30 kg safely
- Suits 1500 mm skip bins
- Compatible with 80, 120 and 240 litre wheelie bins
- Manual assisted lift operation with slow release gas struts
- Suitable for 2 lifts per day, per person
- Fits through internal doorways



Order Code

Niftylift Bin Lifter for 1500 mm skip bins

NIFTYLIFT30

Rugged – Manual

- Full swing bin lifter, lifts up to 100 kg safely
- Models to suit 1500 mm or 1800 mm skip bins
- Compatible with 80, 120, 140 and 240 litre wheelie bins
- Spark free hydraulic hand pump operation
- Suitable for 10 lifts per day, per person
- Fits through internal doorways



Order Code

Rugged Manual Bin Lifter for 1500 mm skip bins

BLHP1500

BLHP1500—lid lifter compatible

BLHP1500LL

Rugged Manual Bin Lifter for 1800 mm skip bins

BLHP1800

Rugged – Powered

- Full swing bin lifter, lifts up to 150 kg safely, up to 50 times per day
- Models to suit 1500 mm or 1800 mm skip bins
- Compatible with 80, 120, 140 and 240 litre wheelie bins
- Battery operated push button hydraulic system
- Fits through internal doorways



Order Code

Rugged Powered Bin Lifter for 1500 mm skip bins

BLEH1500

BLEH1500—lid lifter compatible

BLEH1500LL

Rugged Powered Bin Lifter for 1800 mm skip bins

BLEH1800

Wheelie bin transport

Electrodrive Powered Bin Trolley

- Move up to three 240 L wheelie bins, weighing up to 400 kg over a flat surface
- Powered drive wheel can carry loads over ramps up to 5 degrees
- Smart design with easy turning action
- Tiller control keeps you in front of load



Order Code

Powered Bin Trolley

POWBINTROLLEY

Modular Bin Trailer

- Load capacity of up to 240 kg per bin bay
- Compatible with 80, 120, 140, 240 and 360 litre wheelie bins
- Gas strut actuated bin retention bar
- Fits within one standard car parking space
- Comes with a pin-hitch coupling as standard
- Also available with tow ball or bar hitch couplings



Trailer with optional tow ball coupling shown.

Order Code

Three bay trailer for 80–360 L wheelie bins

MODULAR3

Six bay trailer for 80–360 L wheelie bins

MODULAR6

Ecolift

- Lift-and-tilt bin lifter, lifts up to 50 kg safely
- Suits 1500 mm skip bins
- Compatible with 80, 120, 140 and 240 litre wheelie bins
- Crank handle winding operation for controlled lifting
- Suitable for 6 lifts per day, per person
- Safety cage panels eliminate hand crush points for operators and bystanders



Order Code

Ecolift Bin Lifter for 1500 mm skip bins	ECOLIFT50
--	-----------

Simplicity Plus

- Lift-and-tilt bin lifter, lifts up to 150 kg safely, up to 100 times per day
- Models to suit 1100, 1500 and 1800 mm skip bins
- Compatible with 80, 120, 140 and 240 litre wheelie bins
- Battery operated push button hydraulic system
- Safety cage eliminates hand and foot crush points for operators and bystanders



Order Code

Simplicity Plus for 1100 mm skip bins	SIMPLUS150HY1100
Simplicity Plus for 1500 mm skip bins	SIMPLUS150HY1500
Simplicity Plus for 1800 mm skip bins	SIMPLUS150HY1800

Universal

- Lift-and-tilt bin lifter, lifts up to 250 kg safely, over 100 times per day
- Models to suit 1100, 1500 and 1800 mm skip bins
- Compatible with 80, 120, 140 and 240 litre wheelie bins
- Battery operated push button hydraulic system
- Safety cage and door eliminates all hand and foot crush points for operators and bystanders



Order Code

Universal Bin Lifter for 1100 mm skip bins	UBL250HY1100
Universal Bin Lifter for 1500 mm skip bins	UBL250HY1500
Universal Bin Lifter for 1800 mm skip bins	UBL250HY1800

Bin lifter top point height

If you are planning to install a bin lifter in a covered location, like a basement, consideration needs to be given for the space the bin lifter needs as it tips the wheelie bin into the skip. The table on the left shows the required height clearance for every model.

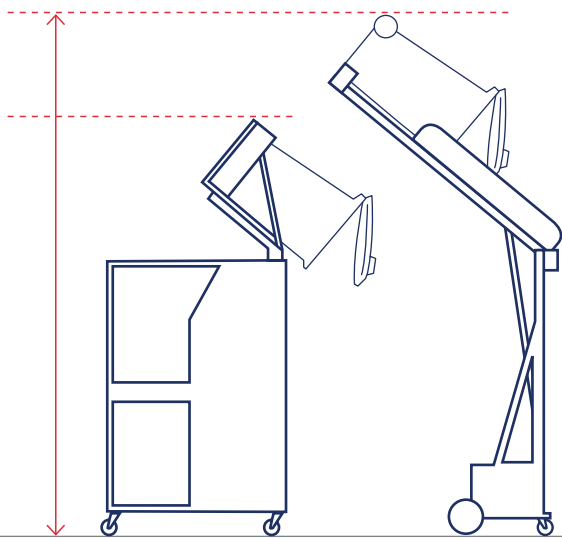

Bin Lifter	Order code	Top point height (mm)
Full swing		
Niftylift	NIFTYLIFT30	2850
Rugged—Manual	BLHP1500, BLHP1500LL	3250
	BLHP1800	3550
Rugged—Powered	BLEH1500, BLEH1500LL	3250
	BLEH1800	3550
Lift-and-tilt		
Ecolift	ECOLIFT50	2800
Simplicity Plus	SIMPLUS150HY1100, SIMPLUS150HY1500, SIMPLUS150HY1800	2900
Universal	UBL250HY1100, UBL250HY1500, UBL250HY1800	2900



Information



Trading Policies

Customer satisfaction policy

We improve our services by listening to any customer complaints. Occasionally customers take the trouble to tell us if our service was less than perfect, but most dissatisfied customers simply cease to deal with us—to our loss. We treasure those who complain—it is only through the trouble they take that we can improve.

We undertake to respond to any complaints within two business days.

We believe you will be happy, but if you are not...

Firstly try to sort it out with our distributor or branch. If you are still unhappy, feel free to contact our Managing Director—Jo Fallshaw directly on +61 3 9300 8542 or email jo@fallshaw.com.au. We are determined to maintain a high standard and continuously strive for perfect quality and service.

Reduction of Hazardous Substances (RoHS) statement of compliance

This is a directive of the European Union (Directive 2002/95/EC) that restricts the use of hazardous materials in the manufacture of various types of electronic and electrical equipment. Hexavalent Chromium is one of these chemicals and has been traditionally used in the zinc plating industry. We hereby certify that our products (sold under the Fallshaw, Electrodrive and Liftmaster brands*) comply with RoHS regulations and do not contain the following banned substances:

- Lead
- Polybrominated Biphenyls
- Pentabromodiphenyl ether (PentaBDE)
- Mercury
- Cadmium
- Polybrominated Diphenyl Ether
- Octabromodiphenyl ether (OctaBDE)
- Hexavalent Chromium.

* For special-ordered products or products sold under other brands, please inquire about RoHS compliance prior to ordering if this is important to you, and we will research the RoHS compliance or otherwise of the particular item concerned and provide a separate written statement.



Certificate of Registration

Fallshaw Holdings Pty Ltd & Electrodrive Pty Ltd

ABN 74 005 237 525 and ABN 68 006 805 232

The above organisation has been independently assessed and certified as having established, documented and implemented a Quality Management System complying with the requirements of:

ISO 9001:2008 Quality Management Systems Requirements

Scope:

This registration covers the Quality Management System for the design, manufacture and distribution of Fallshaw Wheels and Castors and the design, manufacture, sales and service of materials handling equipment.

Location: 2A Ayton Street, North Sunshine VIC 3020

8 Burwood Avenue, North Sunshine VIC 3020

10A Burwood Avenue, North Sunshine VIC 3020

Client #: 315111
Date of issue: 19.05.2016
Date of Certification: 11.12.2015
Expiry Date: 15.09.2018



For and on behalf of the Issuing Authority:

M.S. Hollebrandse
Certification Manager

W.A. Cullinan
Managing Director

Certification Body
ECAAS Pty Ltd
A.C.N. 104 429 295
GPO Box 1818
ADELAIDE, South Australia 5001



www.jas-anz.org/register





Test summaries for wheels and castors

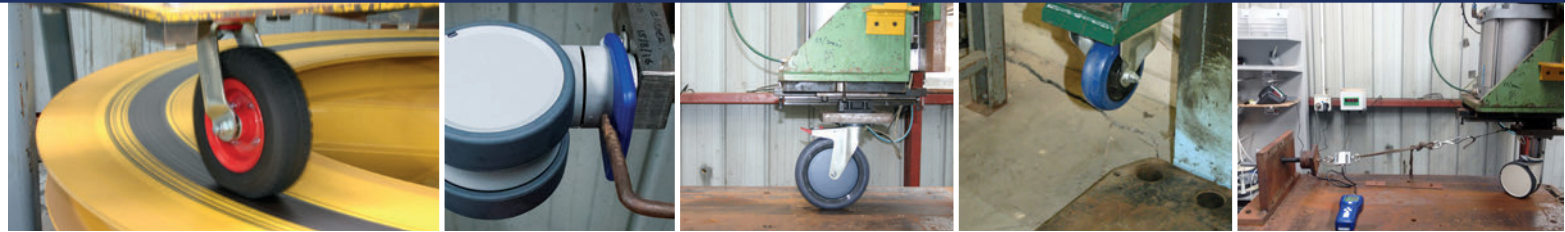

Applicable standards and test methods	Dynamic test	Brake life	Static load test	Impact test	Brake effectiveness
Hospital bed castors IEC60601-2-52 <ul style="list-style-type: none"> Central locking Trinity & Trinity EBC 	1x load capacity with 2.88 km/h speed. Obstacle height 20 mm, 80 mm wide, 90° to travel, 1.5 mm radius on edge. Dynamic run of 10x forward and reverse bumps over obstacle.	Apply brakes 10,000 times without brakes failing.	Apply 3x load capacity for 1 hour. No deformation after 24 hours elapsed time.	N/A	1x load capacity at 10° incline with brakes on. Slippage must be < 10 mm.
Castors for furniture AS1961.3-2004 (ISO 22879:2004) <ul style="list-style-type: none"> Castors with a diameter of 50 mm or less 	Apply 125% of load capacity, 2 mm bump, space 500 cycles, 6.5 cycles/min.	N/A	Apply 2x load capacity for 24 hours. No deformation after 24 hours elapsed time.	30 kg load capacity: 5 kg from 200 mm free fall drop. 40 kg load capacity: 5 kg from 300 mm free fall drop. Proper function (minor deformation allowed).	Load castor to 1x load capacity, then apply horizontal force of 20% of load capacity without brakes allowing wheel to swivel.
Castors for manually propelled equipment for institutional applications—AS1961.5-2004 (ISO 22881:2004) <ul style="list-style-type: none"> Light to medium duty ranges (excluding Economy and castors with diameter < 50 mm) 	1x load capacity at 3 km/h speed. Obstacle height 3% of wheel diameter and with a radius 1/3 of height. Number of obstacles to be 10 times x wheel diameter in mm distance apart 1–3m. Initial swivel play less than 4 mm (measured at 200 mm); final swivel play < 8 mm.	Apply brakes 5,000 times without brakes failing.	Apply 1.5x load capacity for 1 hour. No deformation after 24 hours elapsed time.	N/A	Load castor to 1x load capacity, then apply horizontal force of 20% of load capacity without brakes allowing wheel to swivel.
Applications up to 1.1 m/s (4 km/h)—AS1961.7-2004, ISO 22883:2004 <ul style="list-style-type: none"> General to heavy duty castors 	1x load capacity at 4 km/h speed. Obstacle height: 2.5% of wheel diameter > 90 shore A; 5% of wheel diameter < 90 shore A. Number of obstacles to be 500 and to be 1 m apart, then remainder of 15,000 revolutions of the wheel without obstacles. Initial swivel play < 4 mm (measured at 200 mm). Final swivel play < 8 mm.	Apply brakes 5,000 times without brakes failing.	ABOUT THE BRAKE EFFECTIVENESS TEST The ISO brake effectiveness tests are extremely harsh. They exist to ensure that brakes are ramp-capable by measuring brake traction force. However this greatly reduces the load capacity of the castor that is otherwise appropriate in safely complying with the ISO Static, Dynamic and Impact tests. At Fallshaw, our approach is to rate the castor for normal use on flat surfaces. However if your application involves brake application on ramps or inclines then you MUST reduce the catalogue load rating by 0–40% in order to comply with the ISO brake effectiveness test (except in hospital bed castors which are fully compliant at published ratings).	Load castor to 1x load capacity, then apply horizontal force of X% of load (3 times x 10 seconds) without brake allowing wheel to swivel. X=10% for tyre hardness > 90 shore A X=15% for tyre hardness < 90 shore A.	
Applications over 1.1 m/s (4 km/h) and up to 4.4 m/s (16 km/h) ¹ —AS1961.8-2004 (ISO 22884:2004) <ul style="list-style-type: none"> Very heavy duty castors (excluding Economy range) 	1x load capacity at 6 km/h speed (bumps 1 m apart) and 10 km/h speed (bumps 1.5 m apart). Obstacle height: 2.5% of wheel diameter for tyre hardness > 90 shore A; 5% of wheel diameter < 90 shore A. Number of obstacles at 5 times the wheel diameter. Initial swivel play < 3 mm (measured at 200 mm). Final swivel play < 6 mm.	Apply brakes 5,000 times without brakes failing.		Load castor to 1x load capacity, then apply horizontal force of X% of load (3 times x 10 seconds) without brake allowing wheel to swivel. X=10% for tyre hardness > 90 shore A X=15% for tyre hardness < 90 shore A.	

* The ISO standard for dynamic testing specifies 3 min ON/1 min OFF or 2 min OFF or 3 min OFF. However, we test 3 min ON 3 min OFF in applications where excessive heat build up would not be experienced in the field and is not a failure mode. Change direction each cycle. Obstacles at 45° alternating left/right.

¹ Note that we only provide castors for towing up to 10 km/h.

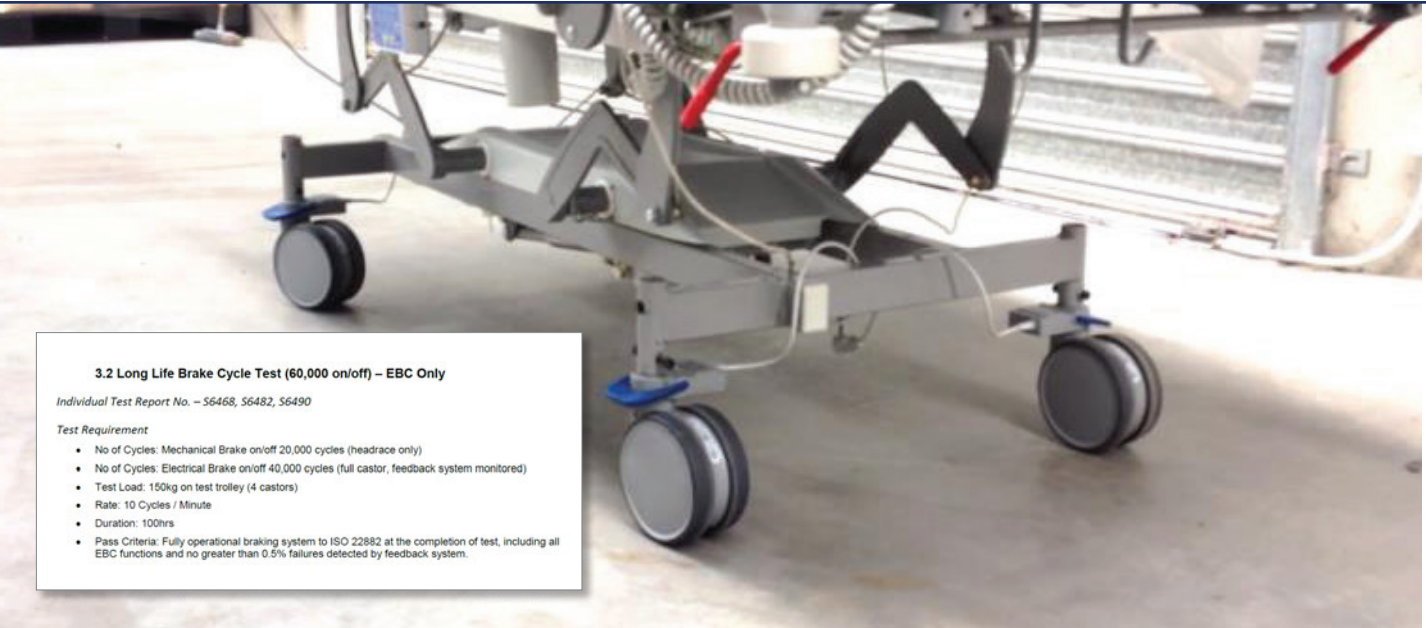

3.2 Long Life Brake Cycle Test (60,000 on/off) – EBC Only
 Individual Test Report No. – S6468, S6482, S6490

Test Requirement

- No of Cycles: Mechanical Brake on/off 20,000 cycles (headrace only)
- No of Cycles: Electrical Brake on/off 40,000 cycles (full castor, feedback system monitored)
- Test Load: 150kg on test trolley (4 castors)
- Rate: 10 Cycles / Minute
- Duration: 100hrs
- Pass Criteria: Fully operational braking system to ISO 22882 at the completion of test, including all EBC functions and no greater than 0.5% failures detected by feedback system.

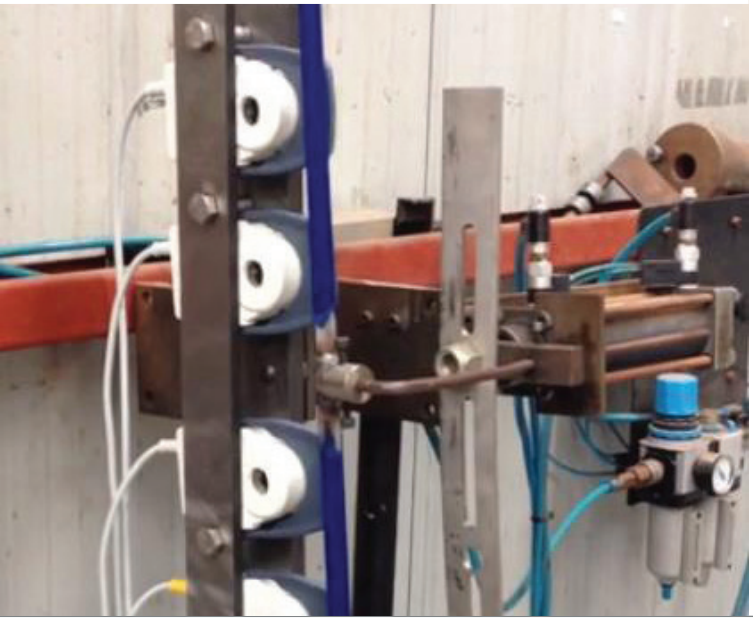

Other standards relevant to Fallshaw products

- Shopping trolleys—For general use—AS/NZS 3847.1:1999
- Shower/toilet chairs (mobile and static)—AS/NZS 3973:2005
- Neutral salt spray (NSS) test—AS2331.3.1-2001
- Powder coating adhesion—AS1580 Method 408.4

And that is only the beginning

We often develop tests in conjunction with our customers to replicate the harsh conditions or long life cycle expectations that will be experienced by products in real world conditions. We can then supply evidence of testing in video format as well as formal test reports.

Here’s one of our favourite examples. One of the 25 tests that Trinity EBC has to pass to meet our standards, is a Long Life Brake Cycle Test. The Trinity EBC has a brake designed for 60,000 brake ON/OFF cycles and we conduct this test over 100 hours, ensuring that Trinity EBC will continue to be dependable out in the field.

1. IEC 60601-2-52 Testing
 - 1.1 Threshold Test
 - 1.1.1 EBC
 - 1.1.2 Trinity 100 (4”)
 - 1.1.2 Trinity 125 (5”)
 - 1.1.3 Trinity 150 (6”)
 - 1.2 Instability in Transport - Ramp Test
 - 1.2.1 Trinity 100 (4”)
 - 1.2.3 Trinity 125 (5”)
 - 1.2.4 Trinity 150 (6”)
 - 1.3 Cable Pullout Test – EBC Only
 - 1.4 Cable Torque Test
2. ISO 22882 (AS 1961.6 2004, EN 12531:1998) Hospital Castor Testing
 - 2.1 Braking Fatigue Test (10,000 on/off)
 - 2.1.3 Trinity 100mm and 150mm
 - 2.1.4 Trinity EBC
 - 2.2 Wheel Braking Test
 - 2.3 Swivel Braking Test
 - 2.3.1 Tested in Total Brake
 - 2.3.2 Tested in Direction Lock
 - 2.4 Static Load Test
 - 2.5 Dynamic Run Test
3. Fallshaw Inhouse Testing
 - 3.1 Long Life Run Test (30,000 Obstacles)
 - 3.1.1 Trinity 100 Pintle and washer mount
 - 3.1.2 Trinity T125 Pintle and washer mount
 - 3.1.2 Trinity 150 EBC
 - 3.1.3 Trinity 150 washer mount
 - 3.1.4 Trinity 150 Pintle Mount
 - 3.2 Long Life Brake Cycle Test (60,000 on/off) – EBC Only
 - 3.3 Dynamic Brake Test – EBC Only
 - 3.4 Side Impact
 - 3.4.1 Tested in Direction Lock
 - 3.4.2 Tested in Total Brake
 - 3.5 Pedal Impact
 - 3.6 Castor Impact
 - 3.7 Linear Swivel Test
 - 3.8 Dynamic Run Test
 - 3.9 Individual Swivel Resistance Test
 - 3.10 Mounted Rolling/Swivel Resistance
 - 3.11 Brake Usage Life Cycle Test – EBC Only
 - 3.12 Intuitive Steer Test
 - 3.13 Direction Lock Side Drag Test
 - 3.14 Direction Lock Bump Test

Test summaries for materials handling equipment

Relevant Legislation & Regulations for all powered materials handling equipment (Bin Lifters, Tugs & Bed Movers)

- Occupational Health and Safety Act 2004 [OH&S Act s40(2)]
- Occupational Health and Safety Regulations 2007 [OH&S Regulations Part 3.5, 6.2.1–6.2.8, Part 1, Schedule 2]
- Equipment (Public Safety) Regulations 2007 [EPS Regulations 801-806, Schedule]
- AS 3000: Wiring Rules
- AS 1319: Safety signs for the occupational environment
- AS 1431: Low Voltage Switchgear and Control gear—Control circuit Devices and Switching Elements.
- AS 1775: Low Voltage Switchgear and Control Gear.
- AS 1939: Classification of degrees of protection provided by enclosures for electrical equipment (IP code).
- AS 2005: Fuses with enclosed fuse links.
- AS 2467: Maintenance of electrical switchgear.
- AS 2700: Colour standards for general purposes.
- AS/NZS 3000: SAA Wiring Rules.
- AS/NZS 3008.1.1: Electrical Installations—selection of cables.
- AS 3147: PVC insulated electric cables and flexible cables for working voltages of up to and including 0.6/1 kV.
- AS 3193: Transformer type battery charges.
- AS/NZS 4836: Safe working on low-voltage electrical installations
- ASC 320: Classification of insulating materials for electrical machinery and apparatus on the basis of thermal stability in service.

Tugs

- AS2359—Powered industrial trucks (AUST)
- AS4024—Safety of machinery (AUST)
- ANSI/ITSDFB56.9-2007, Safety Standard Operator Controlled Industrial Tow Tractors
- (US) Directive 2006/42/EC (EURO)
- AS 1554.1:2011—Structural Steel Welding



Bed Movers

- IEC60601-1
- IEC60601-2-52
- Medical Device Directive (93/42/EEC) (EURO)
- AS 1554.1:2011—Structural Steel Welding



Bin Lifters

- AS4024—Safety of machinery (AUST)
- AS 1554.1:2011—Structural Steel Welding



Production Testing

Pre-assembly

In process

Pre-delivery

In service

Tugs

Bench testing of critical electro-mechanical components including motors & actuators

Current draw test during assembly on electro-mechanical components

- Output performance check
- Record speed & check speed chart
 - Record load test & check load chart
 - Check appropriate labels are fitted

Diagnostics check
Functional assessment check

Bed Movers

Bench testing of critical electro-mechanical components including motors & actuators

Current draw test during assembly on electro-mechanical components

- Output performance check
- Record speed & check speed chart
 - Record load test & check load chart
- Check appropriate labels are fitted

Diagnostics check
Functional assessment check

Bin Lifters

Bench testing of critical electro-mechanical components including motors & actuators

Load testing
Cycle testing of hydraulic system
Inspection of fluids

- Check for fluid leaks
Test limit switch function
Check appropriate labels are fitted

Functional assessment check
Review for worn parts

Delivery Policy

Fallshaw's factory and main stock holding is in Melbourne, Australia. We also carry small stock holdings in Brisbane. We have a national freight policy, whereby we subsidise freight prices from Melbourne to other Australian destinations so that there is no price disadvantage to receiving stock direct from Melbourne rather than from a local branch. This helps us to prevent double-handling and thereby reduce costs. This keeps our prices competitive for all our customers.

This Despatch Policy is the lead time to despatch an order that our sales people can commit to without making separate inquiries to the Production & Assembly Factory. We ensure we have sufficient stock and manufacturing capacity to reliably deliver against these lead times. We can often do better on request, but you'll need to check first. We can also provide customised replenishment and stocking solutions for our account customers, when particular high-volume products are required on an ongoing basis (so goods are packed and ready to be called up against a firm order).

If an order is placed *before* 10am (Melbourne time), goods are available for collection or despatch from 3pm until 4pm the *same* day, and anytime the day after.

If an order is placed *after* 10am (Melbourne time), goods are available for collection or despatch from 12pm until 4pm the *next* day, and anytime the day after that.

Despatch lead times for order quantities

Wheels and castors	1-50 (VHD 1-20)	51-100	101-300	301-500	500+
General castors (except Very Heavy Duty castors—X, V, A)	Same day	2 days	3 days	8 days	Determined upon request
Very Heavy Duty (VHD) castors	3 days	Determined upon request			
Build your own range	Determined upon request				
Trinity and Trinity EBC	3 days	8 days	Determined upon request		
General wheels	Same day	3 days	Determined upon request		
Pneumatic castors and wheels	Same day	3 days	Determined upon request		
Specialised castors and wheels (exceptions noted on product pages)	Determined upon request				
Materials handling equipment	1-2	3-5	6-10	11+	
Electrodrive Powered Tugs, Powered Trolleys, Bed Movers	10 days	16 days	30 days	Determined upon request	
Liftmaster Bin Lifters and Trailers	10 days	16 days	30 days	Determined upon request	

Normal delivery lead times from despatch

Within Australia		International	
Next day	Melbourne, Sydney, Canberra, Adelaide	10-15 days	New Zealand
3 days	Brisbane, most Vic, NSW & ACT regional areas	24-30 days	Asia
5 days	Perth, Hobart, Townsville & Far North Qld	30-35 days	North America
6 days	Kalgoorlie, Alice Springs, Darwin, Launceston	30-35 days	Africa
7 days	Remote areas of Australia	35-40 days	Europe

Express freight options available on request. All days are business days. WA freight departs on Tuesdays and Fridays.



Maintenance and Fitting

Under average conditions of intermittent use, Fallshaw castors will run for 5 years without maintenance. If the castors are in constant use, this reduces to 1 year.

Correct fitting

Castors will not swivel properly unless they are mounted vertically. Otherwise they will track to one side.

Heavy trolleys need plate mountings, but the base of the trolley must be strong enough to withstand the load. Never mount a plate castor by three bolts only. Never skimp on the mounting base.

You can get up to 8 mm of adjustment with washers, or an off cut of tube tightly jammed between leg and castor—but do not let it float. Tighten tubular fittings firmly, but do not over-tighten.

You should retighten castors after 3 months of use, and annually after that. We recommend '3 finger' tightness—the amount of torque you can get onto a standard spanner using your 3 middle fingers.



Tube Fittings

Medium duty castors are often mounted into tubular legs. But again, it is important that these legs stay vertical.

We recommend that the leg never extend more than 125 mm below the nearest support, and (apart from the lightest uses), the tube should be 1.4 mm thick or more. Thinner gauges often split. If you wish to use lighted gauge in the rest of the trolley, insert a sleeve for at least 150 mm where the castor is mounted.

Never put a round expanding fitting into a square tube as when the trolley hits a bump, the tube is likely to elongate, and the castor may fall out. We do have square fittings, and ask that you use them. If for some reason you need to put round into square, then weld an insert sleeve of round tube (remember—our smallest fitting needs 3/4" ID). When using Directional Lock (DL) type castors it is best to use the solid swivel stem and weld or bolt it in—screwed types can become misaligned. To achieve the best performance from the larger 175 mm and 200 mm castors use solid stems.

When fitting expanding stem castors, make sure that the fitting is fully inserted into the tube, with the tube firmly down onto the castor head rivet, before tightening it up (you may have to remove some of the burr on the inside of the tube before you try to push the fitting in). After making sure the weld on the inside of the tube is not excessive, align it with one of the slots down the outside of the adaptor fitting. Put the fitting into the tube all the way, then put some sideways pressure on to it to help the fittings grip, then tighten the stem bolt firmly. Do *not* over-tighten, or you will make it hard to remove later. It is advisable that any tube fitting on expanding stem castors be checked after the first 3 months, and then yearly to make sure the tube fitting is fully and firmly into the tube and the tightening nut is firmly but not over tightened.

Greasing

Grease in both the swivel head race and the wheel serve three purposes:

- Prevents rusting of the balls and raceways
- Prevents galling
- Reduces noise

It does not need a lot of grease to do this. Too much is unsightly and only attracts dust. A liberal smear is all that is needed. If you only have a few castors to grease, use your finger to apply the grease, then wipe off the excess with a rag or use a needle tip grease gun.

If you have many of them we suggest the following:

- Turn the trolley upside down and remove the wheels.
- Re-grease the head, either through the grease nipple if fitted, or by a needle tip fitting on a grease gun. You will need to lift the seal on the heavier range of castors with a sharp pointed screwdriver. Two full squirts are usually adequate, but make sure enough grease gets through to the centre so it can descend to the bottom race.
- Check the wear of the axle bushing. Reuse if not heavily worn, otherwise replace. Smear about a teaspoon of grease along the inside of the wheel bearing with your finger, taking care to force the grease up into the rollers and reassemble.
- Be careful of the lip seal on the wheel as you reinsert the axle bushing into the roller bearing wheels. Make sure the axle bushing is clean as you reinsert it.
- Reassemble the wheel into the castor. Replace washer where fitted. A drop of *Loctite High Assembly Strength* solution on the axle thread is a good precaution.
- Use a No.2 bearing grease (not sodium based).

Wheel Bearings

Any slackness present in plain bearings or roller bearings can often be improved by replacing the axle bushing. If necessary, the plain or roller bearings can be replaced as well. Often simply re-greasing B type bearings is enough, though they can also be replaced if necessary. Sealed precision Q type bearings seldom wear sufficiently enough to need attention.

Preventative maintenance, breakdown repair service, fitting

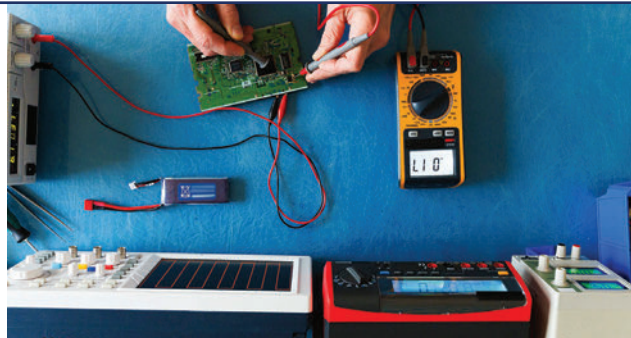

Serviced Equipment

Serviced Equipment is a leading provider of preventative maintenance and breakdown repair services for the health and industrial sectors, and the authorised service agent for Fallshaw and Electrodrive.

Staff are well trained and comply with relevant standards and certification, including but not limited to:

- **iPRO Live certification** (essential within the Healthcare Sector)
- **Electrical safety checks to Standards**—AS/NZS 3760 and 3551
- **Asset management and database management** to comply with AS/NZS 3551

Their work includes providing certificates, service history, tagging and record keeping to ensure full compliance as part of formal audit programs.

Contact Serviced Equipment

Serviced Equipment

Phone: 1300 934 471 (within Australia)
7am – 5pm, Monday – Friday
Email: info@servicedequipment.com.au
Web: www.servicedequipment.com.au

Need castors replaced as part of a trolley refurbishment program?

Our authorised service agent can do the work for you. Their expert knowledge on wheel and castor selection and fitting means you can have the right castor fitted correctly.

What about preventative maintenance programs to keep your Electrodrive equipment in top notch?

The technicians at Serviced Equipment have spare parts and expert product knowledge to keep your Electrodrive equipment running in optimal condition for years.

What about breakdown maintenance?

The technicians at Serviced Equipment are fast and reliable and can often get to you same day or next day to get your Electrodrive equipment back up and running ASAP. If location, time commitments or complexity make this impractical, then loan equipment can be sent to you to use while your unit is returned to base for repairs.

What about testing and tagging?

All our technicians are nationally accredited to test and tag under the *In-service safety inspection and testing of electrical equipment* (AS/NZS 3760:2003) standard. This includes (but not limited to) the test and tagging of batteries, chargers or general power tools and appliances.

Can Serviced Equipment help with general maintenance (not just Electrodrive Equipment)?

Serviced Equipment specialises in servicing electro-mechanical industrial equipment (otherwise known as plant items) across a broad spectrum of downstream industries. Their highly skilled and experienced technicians have the ability to inspect, diagnose and repair almost any fault with an electro-mechanical machine. This might include worn components in a walkie-stacker (smaller forklifts), rewiring a steering controller, calibrating scales, welding and customising specialised trolleys, replacing oil in hydraulic actuators and much more.

Within the healthcare sector, Serviced Equipment's expertise includes servicing:

Patient transportation and handling equipment

- Mobile Floor Hoists
- Wheelchairs
- Power Chairs
- Wheelchair Movers
- Mobility Scooters
- Strollers
- Bed Movers

Kitchen equipment and hospitality services

- Motorised meal delivery systems
- Sluice machines
- Commercial dishwashers
- Ice makers
- Water filtration systems
- Mobility scooters

Laundry equipment

- Tugs and Linen Movers



Warranty



Our products are warranted against defects in materials or workmanship for the following periods:

General castors

- 3 years

Specialised castors

- AGV—3 years
- M Powder coat—1 year
- M Stainless steel—3 years
- O Stainless steel—3 years
- Hi/Low temperature—1 year

Medical castors

- Trinity—3 years
- Central locking—3 years
- Wheelchair—3 years

Decorative castors

- 3 years

Wheels

- Hard—3 years
- Soft—3 years
- Pneumatic—1 year

Powered Tugs and Movers

- Unit—1 year
- Battery—6 months

Bin Lifters

- Unit—1 year
- Battery—6 months

Any product that fails within the warranty period will be replaced with an equivalent product, delivered to the customer's store free of charge and freight cost. The warranty does not extend to the fitting of the product. The website and catalogue specify the conditions of use, installation and maintenance for our products. Customers should choose, use and maintain our product according to our recommendations, or they may become unsafe, our liability may be voided.

This warranty excludes the effects of fair wear and tear, abuse, misuse, improper installation and inadequate maintenance. In unusual or severe applications not clearly similar to those on the website or in the catalogue, the customer is invited to submit a written description of the application against which we will make a recommendation, and which will form a part of the acceptable use conditions of the recommended product. If our catalogue is unclear, or if your application is not clearly covered by the examples given in the catalogue, we ask you to contact our staff for advice. We want to help, and we have the technical information to share if we know your needs.

Conditions of use

Although manufactured in Australia, Fallshaw Wheels & Castors have adopted the general safety standards and conditions of use defined in the *European Union General Product Safety Directive (GPSD) 2001/95/EG (harmonized with the German Law of Liability for Products Prod-HaftG)* as this directive has more extensive product requirements additional to the general requirements of the *Australian Competition and Consumer Act 2010*. Please be advised that our manufacturer's warranty is subject to observing the following information. Deviation from this information will release Fallshaw Wheels & Castors from the manufacturer's liability.

1.0 Product information and determined use

Wheels and castors are defined as constructional parts that are generally interchangeable.

They are fitted to apparatus, furniture, transport systems or similar products to make them mobile.

This product information refers to castors and wheels, particularly to swivel castors (not steer castors) which are used on non-powered equipment at a speed not exceeding walking pace and not being under continuous motion.

Castors and wheels according to this product information, can be divided into the following categories of application:

- Domestic use—such as seating and furniture
- General services—such as shopping trolleys and office equipment
- Health care Services—such as hospital beds and patient trolleys
- Industrial purposes—such as transport equipment with medium and heavy duty load bearing capacities.

Our products will give a long and trouble-free life if the following criteria are adhered to:

1. Correct and secure fitting at the designed position.
2. The fitting must have adequate strength and material for a secure fitting.
3. The function of the castor must not be changed nor affected by the fitting.

4. The swivel action axis must be vertical at all times.
5. Fixed castors must have their wheel axles perpendicular to the direction of travel.
6. If only swivel castors are used, they must be common to each other. If fixed castors are used in conjunction with swivel castors then all castors must be compatible and recommended by the manufacturer.

If castors are used in corrosive environments such as outdoors, coastal areas, corrosive and/or aggressive areas (like chicken farms), and where castors have cleaning regimes requiring water resistance of greater than IPX4, and where castors are exposed to caustic substances, special products have to be specified. See the chemical resistance chart on page 26 for a clear indication of suitability.

For use in temperatures below 5°C and above 30°C, the performance of the castor can be impaired, particularly the normal load capacity as published can be affected when used in temperatures below/above those stated herein. Special products can be specified.

2.0 Misuse

The word 'misuse' is defined as:

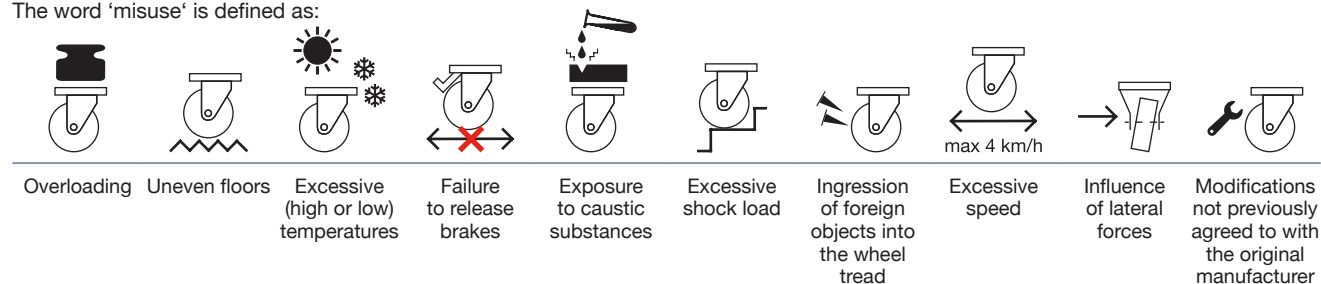

3.0 Product capability

Should the user not find a product clearly described in the manufacturer's catalogue, leaflets or descriptive literature, then any new castor designed for the particular application has to be fully agreed with the manufacturer. Any new designs effected will be subject to the relevant Standards (ISO, IEC etc).

4.0 Maintenance and cleaning

Regular maintenance of castors is required in order to maintain the warranty (as defined in the Maintenance and Fitting section of this catalogue).

Should any cleaning agents be used, then these same agents should not contain corrosive, nor grinding elements. Our products are rated to IPX4 unless otherwise stated on the product page, therefore cleaning with high pressure water (especially if the water is mixed with caustic chemicals and forced into the castor thereby displacing grease or forcing water past seals) will void the warranty. Cleaning should be conducted by following the correct dilution ratio for the cleaning detergent and wiping with a damp cloth.



Choosing castors and wheels

1 Choose the range based on what you are using it for and how much load it will carry

Light to medium duty—L, Twin, N, K, M and Big M

Load rating: 30–200 kg

Suitable for:

- Trolleys and carts
- Shop fittings and displays
- Mobile storage



General duty to heavy duty—J, Y and O Series

Load rating: 200–500 kg

Suitable for:

- Linen carts
- Work platforms
- Roll cages
- Stock trolleys



Very heavy duty—Wastebin, X, V and A Series

Load rating: 500–3500 kg

Suitable for:

- Stock trolleys for automotive plants
- Shipping containers
- Multi-purpose industrial trolleys



Medical—Trinity and Trinity EBC, Central locking, Wheelchair

Load rating: 150 kg

- Medical equipment, hospital beds and other applications that need an automatic or accessible brake
- Recliner chairs
- Mobile computer tables



2 Choose a wheel based on the floor surface it will be travelling on

Outdoors and rough ground

Bouncy, elastic tyres help get over bumps. That's why wheelbarrows and other applications that involve rough ground use pneumatic or rubber tyres.



Soft and smooth floors

Hard wheels have high load bearing capacity and reduce push effort on carpet and soft surfaces, but are very noisy on tiles and other hard surfaces and can also leave indentations on wooden floors.



Variable floor surfaces

Road cases are a classic example of tyres that need to adapt to a wide range of floor surfaces. When bands are on the move, their equipment needs to travel over bitumen, carpet, lino, wood and over curbs and stairs. These wheels go everywhere!



Specialised applications

Some applications have specific requirements, and we have a wide range of wheels to suit, including high and low temperature, wheelie bin wheels, central locking castors, antistatic wheels and many, many more!



3 Choose the wheel's diameter

The larger the wheel, the easier to push and the better the ride comfort (ability to pass over bumps and to minimize vibration).

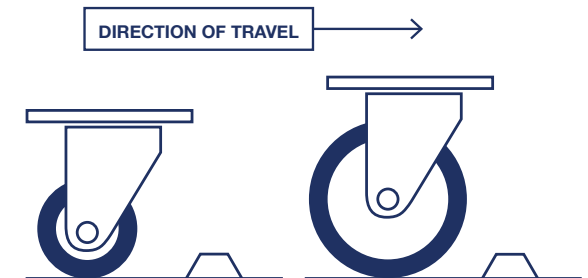

Why? The larger the wheel, the smaller obstacles are in proportion to the wheel's diameter, resulting in greater momentum.

Wheel diameter should be maximised, bearing in mind that:

- As a rule of safety a maximum height of 1400 mm is recommended (including the goods being carried) to enable a clear line of sight.
- Small wheels are sometimes used to reduce the centre of gravity to address tip hazards due to top-heavy loads.

4 Choose the bearing type

Ball

Used in applications where heat can build up due to friction caused by constant movement and/or higher speeds—all towing applications use precision bearings (as the high tolerance and hardened steel used in the sealed and greased bearings reduces heat build-up that can cause weakening of the wheel). Ball bearings offer the lowest friction and therefore the lowest push effort—they are also the most expensive type of bearing in our range.



Roller

Used in high impact applications (the large surface area of the bearing spreads load and therefore protects against high impact). Not suitable for high speed (more than 6 km/h).



Plain bush (or bore)

Used in corrosive environments (polymer bearings won't rust). Also used to reduce cost (the cheapest kind of 'basic' bush).



5 Choose the type of brake and castor configuration

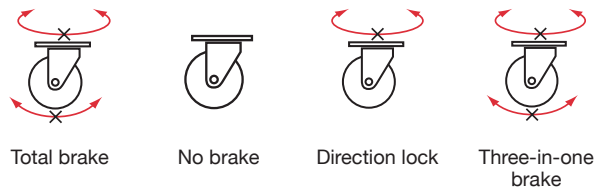

Castor configuration options

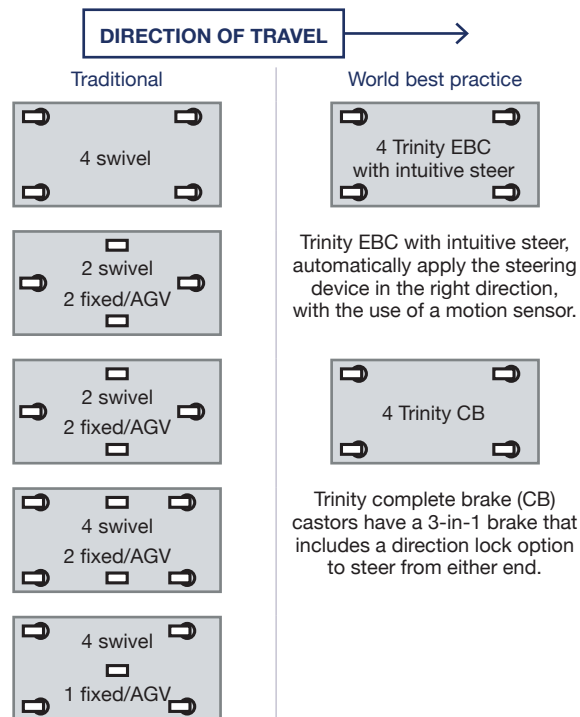

6 Choose fittings

Bolt hole

Suitable for installing into tubular legs. We have a full range of expanding adaptors, pintle bolts, threaded tube ends, grip neck and friction stems and solid pintles, all designed to work seamlessly with any bolt hole castor.



Washer mount (for bolt hole)

Suitable for mounting bolt hole castors into equipment that do not have tubular legs.



Plate mount

Suitable for mounting onto equipment that have smooth flat surfaces, such as sheet metal or wood.



More information on fitting options can be found from page 58–63.



Castor code structure

Wheel series	Tyre material	Bearing	Size (mm)	Extras	Fork series	Fork finish	Mount option	Brake option	Colourway
L	R Black rubber	B Deep groove ball bearing	40	G Thread guard	L	T Painted	P ISO plate mount	TB Total brake, locks swivel and wheel rotation	Arc range
N	S Grey rubber, (flat profile)	Q Precision ball bearing (stainless steel)	50	W White nylon	N	P Powder coated	PN North American plate mount		GH Graphite
TW	T Grey rubber, (round profile)	R Roller bearing	65	S Stainless steel	TW	Z Zinc plated Core Coat™ (with lacquer)	F Fixed plate	DL Direction lock, locks swivel	SL Silver
K	J Thermoplastic elastomer (TPE)	S Roller bearing (stainless steel)	75	T Twin	K	B Basic zinc (no lacquer)	FN North American fixed plate	BR Wheel brake only	WT White
M	A TPE (anti-static)	A Plain bore	100		M	S Stainless steel	H Swivel bolt hole	TS Thumb screw (hand operated wheel brake)	GY Grey
Q	B Blue high resilience rubber	H High temp plain bore	125		D	C Chrome	L Long pintle		Zen range
J	U Polyurethane	I Cast iron plain bore	150		J	B Nylon	S Short pintle		TM Titanium
Y	V PVC	N Nylon plain bore	175		Y	K Nickel	38 3/8" pintle		M Deluxe range
O	N Nylon	T PTFE (teflon) plain bore	200		O		E 12 mm pintle		BN Bluestone
H	H High temperature nylon	K High temp phenolic plain bore	230		X		GN Grip neck pintle		K & M Series
X	V Very high temp phenolic		250		V		J Friction stem		R Red
V	A Cast iron		280		A			SA Self-aligning AGV kit	G Grey
A	F Foamed micro-cellular		300		W			TBSA Self-aligning AGV kit on TB fork	B Black
W	X High impact polymer		400					DLSA Self-aligning AGV kit on DL fork	
			450						

Fork mount dimensions

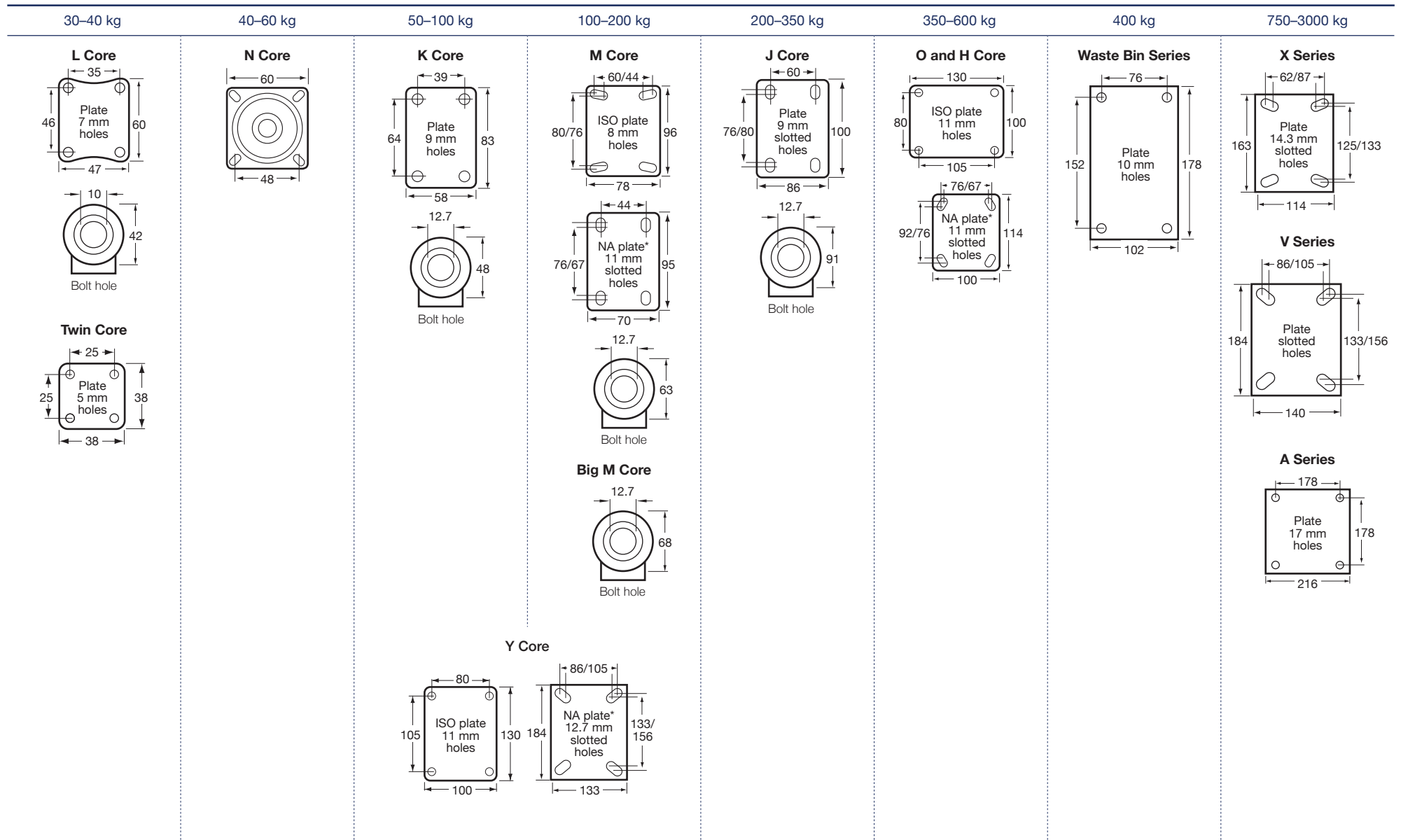

35% of all serious injuries are caused by pushing, pulling or lifting*

We can help you, and your staff, stay safe by providing solutions that eliminate manual materials handling from your workplace. With our range of castors and materials handling equipment, a single operator can move up to ten thousand kilograms safely, without risk of back or shoulder strain. Furthermore, as a solutions provider, we can design and build everything to suit your particular workplace. This means that you, and your staff can do more with less—more productivity, less risk to injury.



** Safe Work Australia 2014 statistics on worker's compensation claims.*

We can help you...



TO THIS

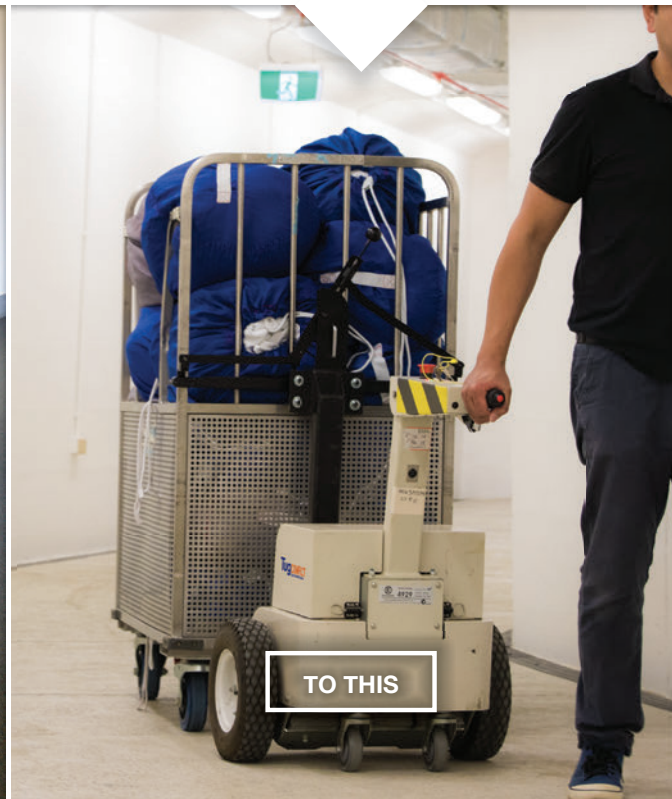
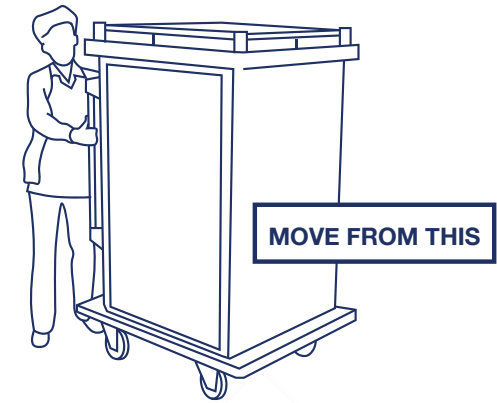
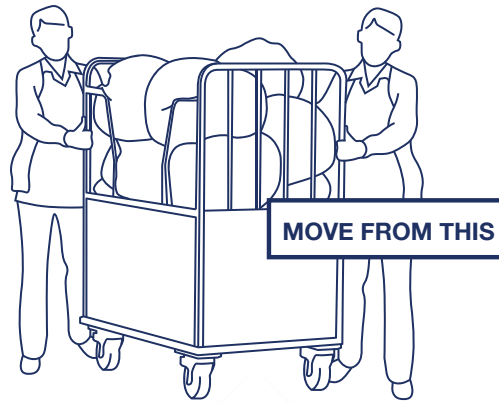
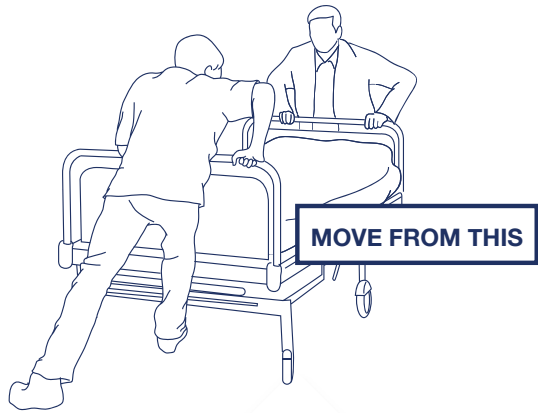



Intelligently simple, smart product design.

Free call: 1800 333 002 (within Australia)
International: +61 3 9300 8555

Victoria

2A Ayton Street
North Sunshine VIC 3020
Australia

New South Wales

5A, 5-7 Meridian Place
Bella Vista NSW 2153
Australia

Queensland

Unit 4/11 Christensen Road
Stapylton QLD 4207
Australia



Fallshaw Wheels & Castors

www.fallshaw.com.au
sales@fallshaw.com.au
ABN: 74 005 237 525



Electrodrive Powered Materials Handling

www.electrodrive.com.au
sales@electrodrive.com.au
ABN: 68 006 805 232